

# **Gate, Globe, and Check Valves for Sizes DN 100 (NPS 4) and Smaller for the Petroleum and Natural Gas Industries**

API STANDARD 602  
TENTH EDITION, MAY 2015

API MONOGRAM PROGRAM EFFECTIVE DATE: NOVEMBER 19, 2015



AMERICAN PETROLEUM INSTITUTE

## Special Notes

API publications necessarily address problems of a general nature. With respect to particular circumstances, local, state, and federal laws and regulations should be reviewed.

Neither API nor any of API's employees, subcontractors, consultants, committees, or other assignees make any warranty or representation, either express or implied, with respect to the accuracy, completeness, or usefulness of the information contained herein, or assume any liability or responsibility for any use, or the results of such use, of any information or process disclosed in this publication. Neither API nor any of API's employees, subcontractors, consultants, or other assignees represent that use of this publication would not infringe upon privately owned rights.

API publications may be used by anyone desiring to do so. Every effort has been made by the Institute to assure the accuracy and reliability of the data contained in them; however, the Institute makes no representation, warranty, or guarantee in connection with this publication and hereby expressly disclaims any liability or responsibility for loss or damage resulting from its use or for the violation of any authorities having jurisdiction with which this publication may conflict.

API publications are published to facilitate the broad availability of proven, sound engineering and operating practices. These publications are not intended to obviate the need for applying sound engineering judgment regarding when and where these publications should be utilized. The formulation and publication of API publications is not intended in any way to inhibit anyone from using any other practices.

Any manufacturer marking equipment or materials in conformance with the marking requirements of an API standard is solely responsible for complying with all the applicable requirements of that standard. API does not represent, warrant, or guarantee that such products do in fact conform to the applicable API standard.

Users of this Standard should not rely exclusively on the information contained in this document. Sound business, scientific, engineering, and safety judgment should be used in employing the information contained herein.

All rights reserved. No part of this work may be reproduced, translated, stored in a retrieval system, or transmitted by any means, electronic, mechanical, photocopying, recording, or otherwise, without prior written permission from the publisher. Contact the Publisher, API Publishing Services, 1220 L Street, NW, Washington, DC 20005.

## Foreword

Nothing contained in any API publication is to be construed as granting any right, by implication or otherwise, for the manufacture, sale, or use of any method, apparatus, or product covered by letters patent. Neither should anything contained in the publication be construed as insuring anyone against liability for infringement of letters patent.

Shall: As used in a standard, "shall" denotes a minimum requirement in order to conform to the specification.

Should: As used in a standard, "should" denotes a recommendation or that which is advised but not required in order to conform to the specification.

This document was produced under API standardization procedures that ensure appropriate notification and participation in the developmental process and is designated as an API standard. Questions concerning the interpretation of the content of this publication or comments and questions concerning the procedures under which this publication was developed should be directed in writing to the Director of Standards, American Petroleum Institute, 1220 L Street, NW, Washington, DC 20005. Requests for permission to reproduce or translate all or any part of the material published herein should also be addressed to the director.

Generally, API standards are reviewed and revised, reaffirmed, or withdrawn at least every five years. A one-time extension of up to two years may be added to this review cycle. Status of the publication can be ascertained from the API Standards Department, telephone (202) 682-8000. A catalog of API publications and materials is published annually by API, 1220 L Street, NW, Washington, DC 20005.

Suggested revisions are invited and should be submitted to the Standards Department, API, 1220 L Street, NW, Washington, DC 20005, [standards@api.org](mailto:standards@api.org).



## Contents

	Page
<b>1 Scope</b> .....	<b>1</b>
<b>2 Normative References</b> .....	<b>2</b>
<b>3 Terms and Definitions</b> .....	<b>3</b>
<b>4 Pressure/Temperature Ratings</b> .....	<b>3</b>
4.1 Valve Ratings .....	3
4.2 Temperature Constraints .....	12
<b>5 Design</b> .....	<b>12</b>
5.1 Reference Design .....	12
5.2 Flow Passageway .....	12
5.3 Wall Thickness .....	12
5.4 Valve Body .....	14
5.5 Valve Bonnet or Cover .....	17
5.6 Closure Element .....	18
5.7 Stem .....	19
5.8 Stem Nut or Stem Bushing .....	21
5.9 Packing, Packing Chamber, and Gland .....	21
5.10 Packing Retention .....	22
5.11 Handwheel .....	22
<b>6 Materials</b> .....	<b>22</b>
6.1 Trim Materials .....	22
6.2 Materials Other Than Trim .....	25
6.3 Compliance .....	25
<b>7 Marking</b> .....	<b>25</b>
7.1 Legibility .....	25
7.2 Body Marking .....	25
7.3 Ring Joint Groove Marking .....	27
7.4 Identification Plate Marking .....	27
7.5 Weld Fabrication Marking .....	27
<b>8 Testing and Inspection</b> .....	<b>28</b>
8.1 Pressure Tests .....	28
8.2 Inspection .....	28
<b>9 Preparation for Dispatch</b> .....	<b>28</b>
<b>10 Purchase Order Information</b> .....	<b>28</b>
<b>Annex A (informative) Use of API Monogram by Licensees</b> .....	<b>29</b>
<b>Annex B (normative) Requirements for Extended Body Valves</b> .....	<b>32</b>
<b>Annex C (normative) Requirements for Valves with Bellows Stem Seals</b> .....	<b>37</b>
<b>Annex D (normative) Type Testing of Bellows Stem Seals</b> .....	<b>41</b>
<b>Annex E (informative) Identification of Valve Parts</b> .....	<b>44</b>
<b>Annex F (normative) Information to be Specified by the Purchaser</b> .....	<b>52</b>
<b>Annex G (informative) Valve Material Combinations</b> .....	<b>54</b>

# Contents

Page

<b>Bibliography</b> .....	<b>57</b>
---------------------------	-----------

## Figures

<b>B.1 Threaded End Extension for Class 800.</b> .....	<b>33</b>
<b>B.2 Welding End Extension for Class 800 and Class 1500</b> .....	<b>33</b>
<b>B.3 Socket Welding End Preparation for Class 800 and Class 1500</b> .....	<b>34</b>
<b>E.1 Outside Screw and Yoke Bolted Bonnet Gate Valve</b> .....	<b>44</b>
<b>E.2 Inside Screw Gate Valve</b> .....	<b>45</b>
<b>E.3 Bellows Stem Seal Gate Valve</b> .....	<b>46</b>
<b>E.4 Welded Bonnet Gate Valve</b> .....	<b>47</b>
<b>E.5 Outside Screw and Yoke Globe Valve</b> .....	<b>48</b>
<b>E.6 Union Bonnet Globe Valve</b> .....	<b>49</b>
<b>E.7 Piston Check Valve</b> .....	<b>50</b>
<b>E.8 Ball Check Valve</b> .....	<b>50</b>
<b>E.9 Swing Check Valve</b> .....	<b>51</b>

## Tables

<b>1a ASME B16.34 Material Group 1, Forging and Casting Descriptions</b> .....	<b>4</b>
<b>1b ASME B16.34 Material Group 2, Forging and Casting Descriptions</b> .....	<b>4</b>
<b>1c ASME B16.34 Material Group 3, Forging and Casting Descriptions</b> .....	<b>4</b>
<b>2a Class 800 Pressure/Temperature Ratings (SI Units)</b> .....	<b>6</b>
<b>2b Class 800 Pressure/Temperature Ratings (USC Units)</b> .....	<b>7</b>
<b>2c Class 800 Pressure/Temperature Ratings (SI Units)</b> .....	<b>8</b>
<b>2d Class 800 Pressure/Temperature Ratings (USC Units)</b> .....	<b>9</b>
<b>2e Class 800 Pressure/Temperature Ratings (SI Units)</b> .....	<b>10</b>
<b>2f Class 800 Pressure/Temperature Ratings (USC Units)</b> .....	<b>11</b>
<b>3 Minimum Diameter of Equivalent Flow Passageway for Standard(1), (2) Bore Valves</b> .....	<b>13</b>
<b>4 Minimum Diameter of Equivalent Flow Passageway for Full-bore(1), (2) Valves</b> .....	<b>13</b>
<b>5 Minimum Wall Thickness for Valve Bodies, Bonnets, and Check Valve Covers</b> .....	<b>14</b>
<b>6 Minimum Wall Thickness for Bonnet Extensions and Bellows Enclosures.</b> .....	<b>15</b>
<b>7 Butt-welding End Diameters</b> .....	<b>17</b>
<b>8 Wear Travel for Gate Valves</b> .....	<b>19</b>
<b>9 Minimum Stem Diameter for Standard Bore Valves</b> .....	<b>20</b>
<b>10 Minimum Stem Diameter for Full-bore Valves</b> .....	<b>20</b>
<b>11 Minimum Uncompressed Packing Height</b> .....	<b>22</b>
<b>12 Nominal Seating Surfaces, Stem, or Weld-Deposited Materials and Hardness.</b> .....	<b>23</b>
<b>13 Alternative CNs</b> .....	<b>25</b>
<b>14 Materials for Valve Parts Other Than Trim Items</b> .....	<b>26</b>
<b>B.1 Threaded End Extension for Class 800.</b> .....	<b>33</b>
<b>B.2 Welding End Extension for Class 800 and Class 1500</b> .....	<b>34</b>
<b>B.3 Socket Welding End Preparation for Class 800 and Class 1500</b> .....	<b>34</b>
<b>B.4 Post weld Heat Treatment.</b> .....	<b>35</b>
<b>C.1 Bellows Material Chart</b> .....	<b>39</b>
<b>D.1 Bellows Test Cycles</b> .....	<b>42</b>
<b>G.1 Material Combinations for Group 1 Body, Bonnet, and Cover Materials</b> .....	<b>54</b>
<b>G.2 Material Combinations for Group 2 Body to Bonnet Materials</b> .....	<b>55</b>
<b>G.3 Material Combinations for Group 3 Body to Bonnet Materials</b> .....	<b>56</b>

# Gate, Globe, and Check Valves for Sizes DN 100 (NPS 4) and Smaller for the Petroleum and Natural Gas Industries

## 1 Scope

This standard specifies the requirements for a series of compact gate, globe and check valves for petroleum and natural gas industry applications.

It is applicable to valves of:

- nominal diameter sizes DN 8, DN 10, DN 15, DN 20, DN 25, DN 32, DN 40, DN 50, DN 65, DN 80, and DN 100;
- corresponding to nominal pipe sizes NPS  $\frac{1}{4}$ , NPS  $\frac{3}{8}$ , NPS  $\frac{1}{2}$ , NPS  $\frac{3}{4}$ , NPS 1, NPS  $1\frac{1}{4}$ , NPS  $1\frac{1}{2}$ , NPS 2, NPS  $2\frac{1}{2}$ , NPS 3, and NPS 4.

It is also applicable to pressure designations of Class 150, Class 300, Class 600, Class 800, and Class 1500.

Class 800 is not a listed class designation, but is an intermediate class number widely used for socket welding and threaded end compact valves.

It includes provisions for the following valve characteristics:

- outside screw with rising stems (OS & Y), in sizes  $8 \leq DN \leq 100$  ( $\frac{1}{4} \leq NPS \leq 4$ ) and pressure designations including Class 800;
- inside screw with rising stems (ISRS), in sizes  $8 \leq DN \leq 65$  ( $\frac{1}{4} \leq NPS \leq 2\frac{1}{2}$ ) and pressure designations of classes  $\leq 800$ ;
- socket welding or threaded ends, in sizes  $8 \leq DN \leq 65$  ( $\frac{1}{4} \leq NPS \leq 2\frac{1}{2}$ ) and pressure designations of Class 800 and Class 1500;
- flanged or butt-welding ends, in sizes  $15 \leq DN \leq 100$  ( $\frac{1}{2} \leq NPS \leq 4$ ) and pressure designations of Class 150 through Class 1500, excluding flanged end Class 800;
- bonnet joint construction—bolted, welded, and threaded with seal weld for classes  $\leq 1500$  and union nut for classes  $\leq 800$ ;
- extended body, in sizes  $15 \leq DN \leq 50$  ( $\frac{1}{2} \leq NPS \leq 2$ ) and pressure designations of Class 800 and Class 1500;
- bellows stem seal, in sizes  $8 \leq DN \leq 50$  ( $\frac{1}{4} \leq NPS \leq 2$ ) and pressure designations of  $\leq$  Class 1500;
- bellows stem seal testing requirements;
- standard and full-bore body seat openings;
- materials, as specified;
- testing and inspection.

This standard is applicable to valve end flanges in accordance with ASME B16.5, valve body ends having tapered pipe threads to ASME B1.20.1, valve body ends having socket weld ends to ASME B16.11 and butt-weld connections per the requirements described within this standard.

If product is supplied bearing the API Monogram and manufactured at a facility licensed by API, the requirements of Annex A shall apply.

## 2 Normative References

The following referenced documents are indispensable for the application of this document. For dated references, only the edition cited applies. For undated references, the latest edition of the referenced document (including any amendments) applies.

API Standard 598, *Valve Inspection and Testing*

API Standard 624, *Type Testing of Rising Stem Valves Equipped with Graphite Packing for Fugitive Emissions*

ASME B1.1<sup>1</sup>, *Unified Inch Screw Threads (UN and UNR Thread Form)*

ASME B1.5, *Acme Screw Threads*

ASME B1.8, *Stub Acme Screw Threads*

ASME B1.13M, *Metric Screw Threads: M Profile*

ASME B1.20.1, *Pipe Threads, General Purpose (Inch)*

ASME B16.5, *Pipe Flanges and Flanged Fittings: NPS 1/2 through NPS 24 Metric/Inch Standard*

ASME B16.10, *Face-to-Face and End-to-End Dimensions of Valves*

ASME B16.11, *Forged Fittings, Socket-welding and Threaded*

ASME B16.34, *Valves-Flanged, Threaded and Welding End*

ASME B31.3, *Process Piping*

ASME Boiler and Pressure Vessel Code (BPVC), *Section IX: Welding and Brazing Qualifications*

ASTM A217<sup>2</sup>, *Standard Specification for Steel Castings, Martensitic Stainless and Alloy, for Pressure-Containing Parts, Suitable for High-Temperature Service*

ASTM A307, *Standard Specification for Carbon Steel Bolts, Studs, and Threaded Rod 60,000 PSI Tensile Strength*

ISO 5752<sup>3</sup>, *Metal valves for use in flanged pipe systems—Face-to-face and centre-to-face dimensions*

ISO 15649, *Petroleum and natural gas industries—Piping*

MSS SP-117<sup>4</sup>, *Bellows Seals for Globe and Gate Valves*

NACE MR 0103<sup>5</sup>, *Materials Resistant to Sulfide Stress Cracking in Corrosive Petroleum Refining Environments*

---

<sup>1</sup> ASME International, 2 Park Avenue, New York, New York 10016-5990, [www.asme.org](http://www.asme.org).

<sup>2</sup> ASTM International, 100 Barr Harbor Drive, West Conshohocken, Pennsylvania 19428, [www.astm.org](http://www.astm.org).

<sup>3</sup> International Organization for Standardization, 1, ch. de la Voie-Creuse, Case postale 56, CH-1211, Geneva 20, Switzerland, [www.iso.org](http://www.iso.org).

<sup>4</sup> Manufacturers Standardization Society of the Valve and Fittings Industry, Inc., 127 Park Street, NE, Vienna, Virginia 22180-4602, [www.mss-hq.com](http://www.mss-hq.com).

<sup>5</sup> NACE International (formerly the National Association of Corrosion Engineers), 1440 South Creek Drive, Houston, Texas 77084-4906, [www.nace.org](http://www.nace.org).



### 3 Terms and Definitions

For the purposes of this document, the following definitions apply.

#### 3.1

##### **Class**

An alphanumeric designation that is used for reference purposes relating to valve pressure/temperature capability, taking into account valve material mechanical properties and valve dimensional characteristics. It comprises the letters "Class" followed by a dimensionless whole number. The number following the letters "Class" do not represent a measurable value and are not used for calculation purposes except where specified in this standard. The allowable pressure for a valve having a class number depends on the valve material and its application temperature and is to be found in tables of pressure/temperature ratings.

#### 3.2

##### **diameter nominal**

##### **DN**

An alphanumeric designation of size that is common for components used in a piping system, used for reference purposes, comprising the letters "DN" followed by a dimensionless number indirectly related to the physical size of the bore or outside diameter of the end connection as appropriate. The dimensionless number following "DN" does not represent a measurable value and is not used for calculation purposes except where specified in this standard.

#### 3.3

##### **nominal pipe size**

##### **NPS**

An alphanumeric designation of size that is common for components used in a piping system, used for reference purposes, comprising the letters "NPS" followed by a dimensionless number indirectly related to the physical size of the bore or outside diameter of the end connection as appropriate. The dimensionless number may be used as a valve size identifier without the prefix "NPS." The dimensionless size identification number does not represent a measurable value and is not used for calculation purposes.

### 4 Pressure/Temperature Ratings

#### 4.1 Valve Ratings

##### 4.1.1 Applicability

The pressure/temperature ratings applicable to valves specified in this standard shall be in accordance with those specified in the tables of ASME B16.34 for standard class for the applicable material specification and class designation.

##### 4.1.2 Applicable Valve Materials

The ASME B16.34 Material Group 1, Material Group 2 forging and casting, and Material Group 3 forging/forged bar, casting, ASTM identifications acceptable for valves constructed under this standard are listed in Table 1a, Table 1b, and Table 1c respectively. The Table 1a, Table 1b, and Table 1c notes apply to the applicable valve material where noted. Not all materials contained in ASME B16.34 are listed in this standard.

##### 4.1.3 Interpolated Ratings

The pressure/temperature ratings for Intermediate Class 800 valves shall be as shown in Table 2a, Table 2b, Table 2c, Table 2d, Table 2e, and Table 2f. The pressure/temperature ratings in Table 2a, Table 2b, Table 2c, Table 2d, Table 2e, and Table 2f are a linear interpolation of Standard Class 600 and Standard Class 900 pressure/temperature ratings listed in ASME B16.34 for the appropriate valve material.

**Table 1a—ASME B16.34 Material Group 1, Forging and Casting Descriptions**

Group	Forgings	Castings
1.1	A105 <sup>a,b</sup> , A350 LF2 <sup>a</sup> , A350 LF3 <sup>d</sup> , A350 LF6 Cl. 1 <sup>c</sup>	A216 WCB <sup>a</sup>
1.2	A350 LF6 Cl. 2 <sup>c</sup>	A352 LC2 <sup>d</sup> , A352 LC3 <sup>d</sup> , A216 WCC <sup>a</sup> , A352 LCC <sup>d</sup>
1.3	N/A	A352 LCB <sup>d</sup> , A217 WC1 <sup>e,f,s</sup> , A352 LC1 <sup>d</sup>
1.4	A350 LF1 <sup>a</sup>	N/A
1.5	A182 F1 <sup>e</sup>	N/A
1.7	A182 F2 <sup>g</sup>	A217 WC4 <sup>f,g,s</sup> , A217 WC5 <sup>f</sup>
1.9	A182 F11 Cl. 2 <sup>f,i</sup>	A217 WC6 <sup>f,h,s</sup>
1.10	A182 F22 Cl. 3 <sup>i</sup>	A217 WC9 <sup>f,h,s</sup>
1.11	A182 F21 <sup>i</sup>	N/A
1.13	A182 F5a	A217 C5 <sup>f,s</sup>
1.14	A182 F9	A217 C12 <sup>f,s</sup>
1.15	A182 F91	A217 C12A <sup>s</sup>
1.17	A182 F12 Cl. 2 <sup>f,i</sup> , A182 F5	N/A
1.18	A182 F92 <sup>r</sup>	N/A

NOTE General notes and footnotes for this table follow Table 1c.

**Table 1b—ASME B16.34 Material Group 2, Forging and Casting Descriptions**

Group	Forgings	Castings
2.1	A182 F304 <sup>j</sup> , A182 F304H	A351 CF3 <sup>k</sup> , A351 CF8 <sup>j</sup> , A351 CF10
2.2	A182 F316 <sup>j</sup> , A182 F316H, A182 F317 <sup>j</sup> ,	A351 CF3M <sup>t</sup> , A351 CF8M <sup>j</sup> , A351 CF3A <sup>d</sup> , A351 CF8A <sup>d</sup> , A351 CG8M <sup>g</sup> , A351 CF10M, A351 CG3M <sup>t</sup>
2.3	A182 F304L <sup>k</sup> , A182 F316L, A182 F317L	N/A
2.4	A182 F321 <sup>g</sup> , A182 F321H <sup>l</sup>	N/A
2.5	A182 F347 <sup>g</sup> , A182 F347H <sup>l</sup> , A182 F348 <sup>g</sup> , A182 F348H <sup>l</sup>	N/A
2.7	A182 F310H	N/A
2.8	A182 F44, A182 F51 <sup>m</sup> , A182 F53 <sup>m</sup> , A182 F55	A351 CK3MCuN, A995 CE8MN <sup>m</sup> , A995 1B, CD4MCuN, A995 6A CD3MWCuN, A995 4A CD3MN
2.10	N/A	A351 CH8 <sup>j</sup> , A351 CH20 <sup>j</sup>
2.11	N/A	A351 CF8C <sup>j</sup>
2.12	N/A	A351 CK20 <sup>j</sup>

NOTE General notes and footnotes for this table follow Table 1c.

**Table 1c—ASME B16.34 Material Group 3, Forging and Casting Descriptions**

Group	Forgings/Forged Bar	Castings
3.1	B462 N08020 <sup>n</sup>	
3.2	B564 N02200 <sup>n</sup>	
3.4	B564 N04400 <sup>n</sup>	A494 M35-1 <sup>n</sup>
	—	A494 M35-2 <sup>n</sup>
3.5	B564 N06600 <sup>n</sup>	
3.6	B564 N08800 <sup>n</sup>	
3.7	B462 N10665 <sup>n</sup>	
	B564 N10665 <sup>n</sup>	
	B462 N10675 <sup>n</sup>	
	B564 N10675 <sup>n</sup>	

**Table 1c—ASME B16.34 Material Group 3, Forging and Casting Descriptions (Continued)**

Group	Forgings/Forged Bar	Castings
3.8	B462 N10276 <sup>o p</sup> B564 N10276 <sup>o p</sup> B564 N06625 <sup>n q</sup> B564 N08825 <sup>n g</sup> B462 N06022 <sup>o p</sup> B564 N06022 <sup>o p</sup> B462 N06200 <sup>o p</sup> B564 N06200 <sup>o p</sup>	
3.12	B462 N08367 <sup>o</sup> B564 N06035 <sup>o k</sup>	A351 CN3MN <sup>o</sup>
3.13	B564 N08031 <sup>n</sup>	
3.15	B564 N08810 <sup>o</sup> — —	— A494 N-12MV <sup>o g</sup> A494 CW-12MW <sup>o g</sup>
3.17	—	A351 CN7M <sup>o</sup>

**General**

NOTE 1 ASME Boiler and Pressure Vessel Section II material that also meet the requirements of the listed ASTM specification may also be used.

NOTE 2 Material limitation, restriction, and special requirements are noted (superscripts) in Table 1a, Table 1b, and Table 1c. See Footnotes.

**Footnotes**

- a Upon prolonged exposure to temperatures above 425 °C (800 °F), the carbide phase of steel may be converted to graphite. Permissible, but not recommended for prolonged use above 425 °C (800 °F).
- b Only killed steel shall be used above 455 °C (850 °F).
- c Not to be used over 260 °C (500 °F).
- d Not to be used over 345 °C (650 °F).
- e Upon prolonged exposure to temperatures above 470 °C (875 °F), the carbide phase of steel of carbon-molybdenum steel may be converted to graphite. Permissible, but not recommended for prolonged use above 470 °C (875 °F).
- f Use normalized and tempered material only.
- g Not to be used over 538 °C (1000 °F).
- h Not to be used over 595 °C (1100 °F).
- i Permissible, but not recommended for prolonged use above 595 °C (1100 °F).
- j At temperatures over 538 °C (1000 °F), use only when the carbon content is 0.04 % or higher.
- k Not to be used over 425 °C (800 °F).
- l At temperatures over 538 °C (1000 °F), use only if the material is heat treated by heating to a minimum temperature of 1095 °C (2000 °F).
- m This steel may become brittle after service at moderately elevated temperatures. Not to be used over 315 °C (600 °F).
- n Use annealed material only.
- o Only use solution annealed material.
- p Not to be used over 675 °C (1250 °F).
- q Not to be used over 645 °C (1200 °F). Alloy N06625 in the annealed condition is subject to severe loss of impact strength at room temperatures after exposure in the range of 538 °C (1000 °F) to 760 °C (1400 °F).
- r Application above 620 °C (1150 °F) is limited to tubing of maximum outside diameter of 88.9 mm (3½ in.).
- s The deliberate addition of any element not listed in Table 1 of ASTM A217 is prohibited, except that calcium (Ca) and Manganese (Mn) may be added for deoxidation.
- t Not to be used over 455 °C (850 °F).





**Table 2c—Class 800 Pressure/Temperature Ratings (SI Units)**

<b>ASME B16.34 Material Group 2 (MPa)</b>										
<b>Temperature (°C)</b>	<b>2.1</b>	<b>2.2</b>	<b>2.3</b>	<b>2.4</b>	<b>2.5</b>	<b>2.7</b>	<b>2.8</b>	<b>2.10</b>	<b>2.11</b>	<b>2.12</b>
-29 to 38	13.24	13.24	11.03	13.24	13.24	13.24	13.79	12.36	13.24	12.36
50	12.75	12.83	10.67	12.95	13.00	12.90	13.79	11.86	13.00	11.86
100	10.90	11.25	9.28	11.80	12.08	11.57	13.51	10.01	12.08	10.01
150	9.87	10.27	8.37	10.93	11.32	10.67	12.25	9.31	11.32	9.31
200	9.19	9.51	7.78	10.21	10.65	10.03	11.38	8.94	10.65	8.94
250	8.67	8.90	7.32	9.61	10.08	9.54	10.79	8.69	10.08	8.69
300	8.24	8.43	6.95	9.10	9.63	9.19	10.36	8.46	9.63	8.46
325	8.06	8.24	6.79	8.88	9.43	9.03	10.18	8.32	9.43	8.32
350	7.90	8.09	6.68	8.69	9.27	8.88	10.04	8.15	9.27	8.15
375	7.74	7.97	6.60	8.54	9.12	8.76	9.96	7.96	9.12	7.96
400	7.58	7.85	6.48	8.43	9.04	8.65	9.76	7.76	9.04	7.76
425	7.47	7.77	6.36	8.30	8.96	8.57		7.56	8.96	7.56
450	7.31	7.69	6.24	8.22	8.92	8.45		7.36	8.92	7.36
475	7.18	7.64		8.14	8.45	8.33		7.13	8.45	7.13
500	7.07	7.53		7.53	7.53	7.53		6.89	7.53	6.89
538	6.52	6.68		6.68	6.68	6.68		6.22	6.68	6.22
550	6.28	6.65		6.65	6.65	6.65		5.84	6.65	6.12
575	5.56	6.38		6.38	6.38	5.91		4.93	6.38	5.78
600	4.50	5.31		5.40	5.71	4.47		3.87	5.28	5.17
625	3.68	4.21		4.21	4.88	3.33		3.05	3.70	4.49
650	3.00	3.38		3.37	3.77	2.50		2.37	2.75	3.75
675	2.49	2.75		2.63	3.35	1.93		1.86	2.12	3.07
700	2.14	2.23		2.11	2.65	1.47		1.51	1.49	2.34
725	1.80	1.87		1.69	2.06	1.16		1.22	1.06	1.69
750	1.54	1.56		1.33	1.56	0.91		0.93	0.83	1.19
775	1.21	1.21		1.06	1.21	0.71		0.68	0.66	0.84
800	0.93	0.93		0.84	0.93	0.55		0.54	0.54	0.61

**Table 2d—Class 800 Pressure/Temperature Ratings (USC Units)**

<b>ASME B16.34 Material Group 2</b> (psi)										
<b>Temperature (°F)</b>	<b>2.1</b>	<b>2.2</b>	<b>2.3</b>	<b>2.4</b>	<b>2.5</b>	<b>2.7</b>	<b>2.8</b>	<b>2.10</b>	<b>2.11</b>	<b>2.12</b>
-20 to 100	1920	1920	1600	1920	1920	1920	2000	1790	1920	1790
200	1600	1655	1365	1730	1765	1695	1985	1465	1765	1465
300	1435	1495	1215	1585	1645	1545	1780	1350	1645	1350
400	1325	1370	1120	1470	1535	1445	1640	1295	1535	1295
500	1240	1275	1050	1375	1445	1370	1545	1255	1445	1255
600	1180	1205	990	1300	1375	1320	1485	1215	1375	1215
650	1150	1180	975	1265	1350	1295	1460	1190	1350	1190
700	1125	1160	960	1240	1325	1275	1445	1160	1325	1160
750	1100	1140	940	1220	1310	1255	1420	1125	1310	1125
800	1080	1125	920	1205	1300	1240		1095	1300	1095
850	1055	1115	900	1190	1295	1220		1060	1295	1060
900	1035	1105		1180	1200	1200		1025	1200	1025
950	1020	1030		1030	1030	1030		985	1030	985
1000	945	970		970	970	970		900	970	900
1050	865	960		960	960	940		780	960	865
1100	685	815		830	860	695		595	830	780
1150	545	630		630	735	500		460	555	665
1200	440	495		495	550	365		345	405	545
1250	355	390		375	485	275		265	300	440
1300	300	310		295	365	200		210	200	320
1350	250	255		225	275	155		165	140	220
1400	200	200		175	200	120		120	110	145
1450	155	155		140	155	90		85	85	100
1500	110	110		100	110	65		70	70	70

**Table 2e—Class 800 Pressure/Temperature Ratings (SI Units)**

<b>ASME B16.34 Material Group 3 (MPa)</b>											
<b>Temperature (°C)</b>	<b>3.1</b>	<b>3.2</b>	<b>3.4</b>	<b>3.5</b>	<b>3.6</b>	<b>3.7</b>	<b>3.8</b>	<b>3.12</b>	<b>3.13</b>	<b>3.15</b>	<b>3.17</b>
-29 to 38	13.79	8.83	11.03	13.79	13.24	13.79	13.79	12.36	13.79	11.03	11.03
50	13.79	8.83	10.73	13.79	13.01	13.79	13.79	12.15	13.79	10.84	10.7
100	13.56	8.83	9.58	13.74	12.17	13.74	13.74	11.34	12.84	10.08	9.41
150	13.05	8.83	9.00	13.38	11.73	13.38	13.38	10.70	12.21	9.56	8.54
200	12.58	8.83	8.72	12.96	11.41	12.96	12.89	9.95	11.62	9.05	7.83
250	12.13	8.43	8.69	12.36	11.13	12.36	12.36	9.31	11.06	8.60	7.26
300	11.43	7.80	8.69	11.43	10.89	11.43	11.43	8.83	10.5	8.20	6.77
325	11.02	5.01	8.69	11.02	10.75	11.02	11.02	8.62	10.25	8.02	6.51
350	10.73		8.68	10.73	10.60	10.73	10.73	8.43	10.06	7.85	
375	10.35		8.64	10.35	10.35	10.35	10.35	8.27	9.91	7.66	
400	9.74		8.55	9.76	9.76	9.76	9.76	8.11	9.76	7.54	
425	9.34		8.44	9.34	9.34	9.34	9.34	7.96	9.34	7.38	
450			7.17	9.02	9.02		9.02			7.26	
475			5.54	8.45	8.45		8.45			7.14	
500				7.53	7.53		7.53			7.02	
538				4.41	6.68		6.68			6.68	
550				3.72	6.65		6.65			6.65	
575				2.52	6.38		6.38			6.38	
600				1.77	5.71		5.71			5.71	
625				1.37	4.88		4.88			4.88	
650				1.26	3.77		3.75			3.77	
675					2.74		3.07			3.35	
700					1.48		2.34			2.65	
725					1.08					2.06	
750					0.81					1.56	
775					0.66					1.21	
800					0.58					0.93	
816					0.51					0.77	



**Table 2f—Class 800 Pressure/Temperature Ratings (USC Units)**

<b>ASME B16.34 Material Group 3</b> (psi)											
<b>Temperature (°F)</b>	<b>3.1</b>	<b>3.2</b>	<b>3.4</b>	<b>3.5</b>	<b>3.6</b>	<b>3.7</b>	<b>3.8</b>	<b>3.12</b>	<b>3.13</b>	<b>3.15</b>	<b>3.17</b>
-20 to 100	2000	1280	1600	2000	1920	2000	2000	1790	2000	1600	1600
200	1980	1280	1400	2000	1775	2000	2000	1660	1875	1470	1380
300	1895	1280	1305	1940	1700	1940	1940	1555	1775	1385	1240
400	1820	1280	1260	1880	1655	1880	1860	1435	1675	1305	1125
500	1745	1210	1260	1775	1605	1775	1775	1335	1585	1235	1035
600	1615	1100	1260	1615	1570	1615	1615	1260	1500	1175	960
650	1570		1260	1570	1540	1570	1570	1225	1465	1145	
700	1515		1255	1515	1515	1515	1515	1205	1440	1115	
750	1420		1240	1420	1420	1420	1420	1180	1420	1095	
800	1355		1220	1355	1355	1355	1355	1150	1355	1065	
850			1005	1300	1300		1300			1050	
900			735	1200	1200		1200			1030	
950				970	1030		1035			1015	
1000				640	970		970			970	
1050				415	960		960			935	
1100				275	860		860			860	
1150				200	735		735			735	
1200				180	550		545			550	
1250					385		440			485	
1300					180		320			365	
1350					145					275	
1400					100					200	
1450					95					155	
1500					70					110	

## 4.2 Temperature Constraints

**4.2.1** The temperature for a corresponding pressure rating is the maximum temperature of the pressure-containing shell of the valve. In general, this temperature is the same as that of the contained fluid. The use of a pressure rating corresponding to a temperature other than that of the contained fluid is the responsibility of the user.

**4.2.2** Restrictions of temperature and pressure, e.g. those imposed by special soft seals, special trim materials, packing, or bellows stem seals, shall be marked on the valve identification plate (see 7.4).

**4.2.3** For temperatures below the lowest temperature listed in the pressure/temperature rating tables (see 4.1), the service pressure shall be no greater than the pressure for the lowest listed temperature. The use of valves at lower than the lowest listed temperature is the responsibility of the user. Consideration shall be given to the loss of ductility and toughness of many materials at low temperature. ASME B31.3 and ASME B31T may be used as guidance. Additional information for cryogenic service valves with body/bonnet extensions can be found in MSS SP-134 and ISO 28921-1.

## 5 Design

### 5.1 Reference Design

**5.1.1** Requirements for extended body valves are given in Annex B and those for bellows stem seals in Annex C and Annex D. Other configurations and types of material may be provided when specified in accordance with Annex F.

**5.1.2** Valve parts are identified in Annex E.

**5.1.3** The reference design (the design to be provided when the purchaser does not specify otherwise or does not use Annex F) for sizes  $DN \leq 100$  ( $NPS \leq 4$ ) is for standard bore, bolted-bonnet or cover construction, an outside stem thread for gate and globe valves and, for globe valves, has a conical disc. The reference design for threaded-end valves uses taper pipe threads in accordance with ASME B1.20.1. In addition, for valves  $DN \leq 50$  ( $NPS \leq 2$ ), the reference design is to have a body and bonnet or cover of forged material.

### 5.2 Flow Passageway

**5.2.1** The flow passageway includes the seat opening and the body ports leading to that opening. The body ports are the intervening elements that link the seat opening to the end connection (e.g. socket or flange).

**5.2.2** The minimum cross-sectional area requirement for the standard bore flow passageway applies for both the valve body ports and the seat opening in the absence of the valve disc. The minimum flow passageway cross-sectional area shall not be less than that obtained using the diameters in Table 3.

**5.2.3** The minimum cross-sectional area requirement for the full-bore flow passageway (except extended body valves) applies for both the valve body ports and the seat opening in the absence of the valve disc. The minimum flow passageway cross-sectional area shall not be less than that obtained using the diameters in Table 4. This standard does not provide for extended body valves (see Annex B) with full-bore openings.

### 5.3 Wall Thickness

**5.3.1** Except as provided for in 5.3.2 and 5.3.3, the minimum wall thickness values for valve bodies, bonnets and check valve covers are given in Table 5. The manufacturer, taking into account such factors as bonnet bolting loads, rigidity needed for stem alignment, valve design details and the specified operating conditions, is responsible for determining if a larger wall thickness is required.

**Table 3—Minimum Diameter of Equivalent Flow Passageway for Standard<sup>(1)</sup>, <sup>(2)</sup> Bore Valves**

DN	Minimum Diameter mm (in.)			NPS
	Class 150, Class 300, Class 600, Class 800	Class 1500		
		Gate, Globe, or Check Valves	Gate Valves	
8	6 (1/4)	6 (1/4)	5 (3/16)	1/4
10	6 (1/4)	6 (1/4)	5 (3/16)	3/8
15	9 (3/8)	9 (3/8)	8 (5/16)	1/2
20	12 (1/2)	12 (1/2)	9 (3/8)	3/4
25	17 (11/16)	15 (5/8)	14 (9/16)	1
32	23 (15/16)	22 (7/8)	20 (13/16)	1 1/4
40	28 (1 1/8)	27 (1 1/16)	25 (1)	1 1/2
50	36 (1 7/16)	34 (1 3/8)	27 (1 1/16)	2
65	44 (1 3/4)	38 (1 1/2)	34 (1 3/8)	2 1/2
80	50 (2)	47 (1 7/8)	42 (1 11/16)	3
100	69 (2 3/4)	63 (2 1/2)	58 (2 5/16)	4

NOTE 1 The minimum diameter dimensions shown in this table are identical to the inch dimensions shown in API 602, Ninth Edition, and identical to the millimeter dimensions shown in API 602, Eighth and Ninth Editions.

NOTE 2 Either the metric or US Customary dimension may be used to determine the acceptability of the flow passageway.

**Table 4—Minimum Diameter of Equivalent Flow Passageway for Full-bore<sup>(1)</sup>, <sup>(2)</sup> Valves**

DN	Minimum Diameter mm (in.)			NPS
	Class 150, Class 300, Class 600, Class 800	Class 1500		
		Gate, Globe, or Check Valves	Gate Valves	
8	6 (1/4)	6 (1/4)	4 (3/16)	1/4
10	9 (3/8)	9 (3/8)	7 (5/16)	3/8
15	12 (1/2)	12 (1/2)	9 (3/8)	1/2
20	17 (11/16)	15 (5/8)	14 (9/16)	3/4
25	22 (15/16)	22 (7/8)	19 (13/16)	1
32	28 (1 1/8)	26 (1 1/16)	25 (1)	1 1/4
40	35 (1 7/16)	34 (1 3/8)	26 (1 1/16)	1 1/2
50	44 (1 3/4)	38 (1 1/2)	34 (1 3/8)	2
65	50 (2)	47 (1 7/8)	42 (1 11/16)	2 1/2
80	69 (2 3/4)	63 (2 1/2)	58 (2 5/16)	3
100	95 (3 3/4)	92 (3 5/8)	87 (3 7/16)	4

NOTE 1 Some full-port valves meeting the listed diameters may not meet the "full port" requirements of API 603 or API 600 gate valves.

NOTE 2 Either the metric or US Customary dimension may be used to determine the acceptability of the flow passageway.

**Table 5—Minimum Wall Thickness for Valve Bodies, Bonnets, and Check Valve Covers**

DN	Minimum Wall Thickness mm (in.)		NPS
	Class 150, Class 300, Class 600, Class 800	Class 1500	
8	3.3 (0.13)	3.8 (0.15)	1/4
10	3.6 (0.14)	4.3 (0.17)	3/8
15	4.1 (0.16)	4.8 (0.19)	1/2
20	4.8 (0.19)	6.1 (0.24)	3/4
25	5.8 (0.23)	7.1 (0.28)	1
32	6.1 (0.24)	8.4 (0.33)	1 1/4
40	6.6 (0.26)	9.7 (0.38)	1 1/2
50	7.4 (0.29)	11.9 (0.47)	2
65	8.4 (0.33)	14.2 (0.56)	2 1/2
80	9.7 (0.38)	16.5 (0.65)	3
100	11.9 (0.47)	21.3 (0.84)	4

If the "minimum flow passage and/or 0.9 x basic inside diameter at valve end" > NPS, the wall thickness determination shall be per B16.34, Section 6 rules.

NOTE Wall thickness values listed for Class 150, Class 300, and Class 600 are those required for Class 800 on the assumption that flanged end and butt-welding end valve bodies of these lower nominal pressures would have extensions added (integral or welded) to Class 800 valve bodies.

**5.3.2** Valve body end connection minimum wall thickness shall be in accordance with 5.4.2, 5.4.3, 5.4.4, or 5.4.5 as applicable. Valves identified as extended body valves shall have body extension minimum wall thickness in accordance with A.3. Valves having bellows stem seals with a bellows enclosure shall have a bellows enclosure extension minimum wall thickness in accordance with B.4.

**5.3.3** The bonnet minimum wall thickness for gate or globe valves, except for the neck extension that forms the packing chamber entryway, shall be in accordance with Table 5. The packing chamber extension shall have a local minimum wall thickness as specified in Table 6, based on the local inside diameter of the packing and stem hole.

## 5.4 Valve Body

### 5.4.1 General

Requirements for a basic valve body and associated end connections are given here. See Annex B for requirements for gate and globe valve bodies having extended ends.

### 5.4.2 Socket-welding Ends

**5.4.2.1** Socket-welding-end preparation, including the internal ends of extended-body valves, shall conform to ASME B16.11. The bottom of the socket shall be square and flat, except in the case where a threaded end valve is converted to a socket-weld end valve. The minimum wall thickness of internal socket-welding ends shall be in accordance with the Class 800 or Class 1500 requirements of ASME B16.34, *Minimum Wall Thickness for Socket Welding and Threaded End*.

NOTE Additional guidance on converting a threaded-end valve into a socket-weld end can be found in MSS SP-141, *Multi-Turn and Check Valve Modifications*.

**5.4.2.2** End-to-end dimensions for socket-welding end valves shall be established by the manufacturer.

**Table 6—Minimum Wall Thickness for Bonnet Extensions and Bellows Enclosures**

Extension Inside Diameter mm (in.)	Class 150	Class 300	Class 600	Class 800	Class 1500
	Minimum Wall Thickness mm (in.)				
15 (0.60)	3.1 (0.12)	3.3 (0.13)	3.6 (0.14)	4.0 (0.16)	4.8 (0.19)
16 (0.63)	3.2 (0.125)	3.4 (0.13)	3.8 (0.15)	4.3 (0.17)	5.1 (0.20)
17 (0.67)	3.2 (0.125)	3.4 (0.13)	3.8 (0.15)	4.3 (0.17)	5.1 (0.20)
18 (0.71)	3.3 (0.13)	3.5 (0.14)	3.9 (0.15)	4.4 (0.17)	5.3 (0.21)
19 (0.75)	3.4 (0.13)	3.6 (0.14)	4.0 (0.16)	4.6 (0.18)	5.5 (0.22)
20 (0.78)	3.4 (0.13)	3.6 (0.14)	4.1 (0.16)	4.7 (0.19)	5.7 (0.22)
25 (0.98)	3.8 (0.15)	4.1 (0.16)	4.5 (0.18)	5.4 (0.21)	6.7 (0.26)
30 (1.18)	4.2 (0.165)	4.6 (0.18)	5.0 (0.20)	6.0 (0.24)	7.9 (0.31)
35 (1.38)	4.6 (0.18)	5.1 (0.20)	5.4 (0.21)	6.4 (0.25)	9.0 (0.35)
40 (1.57)	4.9 (0.19)	5.5 (0.22)	5.7 (0.22)	6.7 (0.26)	9.9 (0.39)
50 (1.97)	5.5 (0.22)	6.3 (0.25)	6.3 (0.25)	7.3 (0.29)	11.8 (0.46)
60 (2.36)	5.7 (0.22)	6.6 (0.26)	6.6 (0.26)	8.1 (0.32)	13.6 (0.54)
70 (2.75)	5.9 (0.23)	6.9 (0.27)	7.3 (0.29)	9.0 (0.35)	15.5 (0.61)
80 (3.15)	6.1 (0.24)	7.2 (0.28)	8.0 (0.31)	9.9 (0.39)	17.3 (0.68)
90 (3.54)	6.3 (0.25)	7.5 (0.30)	8.6 (0.34)	10.8 (0.42)	19.1 (0.75)
100 (3.94)	6.5 (0.26)	7.8 (0.31)	9.3 (0.36)	11.8 (0.46)	21.0 (0.83)
110 (4.33)	6.5 (0.26)	8.0 (0.31)	10.0 (0.40)	12.7 (0.50)	22.8 (0.89)
120 (4.72)	6.7 (0.26)	8.3 (0.32)	10.7 (0.42)	13.6 (0.54)	24.7 (0.97)
130 (5.12)	6.8 (0.27)	8.7 (0.34)	11.4 (0.45)	14.5 (0.57)	26.5 (1.02)
140 (5.51)	7.0 (0.28)	9.0 (0.35)	12.0 (0.47)	15.5 (0.61)	28.4 (1.12)

NOTE For bellows enclosures, see B.4.

### 5.4.3 Threaded Ends

**5.4.3.1** The threaded end thread axis shall coincide with the end entry axis. The minimum wall thickness at the threaded end shall be in accordance with ASME B16.34, *Minimum Wall Thickness for Socket Welding and Threaded End*. An approximate 45° lead-in chamfer, having an approximate depth of one-half the thread pitch, shall be applied at each threaded end.

**5.4.3.2** The end threads shall be taper pipe threads meeting the requirements of ASME B1.20.1.

**5.4.3.3** Threads shall be gauged in accordance with ASME B1.20.1.

**5.4.3.4** End-to-end dimensions for threaded end valves shall be established by the manufacturer.

#### 5.4.4 Flanged Ends

**5.4.4.1** End flanges shall comply with the dimensional requirements (flange facing, nut bearing surfaces, outside diameter, thickness, and drilling) of ASME B16.5. Unless otherwise specified, raised face end flanges shall be provided. This standard does not provide for flanged ends for Class 800 valves.

**5.4.4.2** End flanges and bonnet flanges shall be cast or forged integral with, or inertial<sup>6</sup> welded to, the body, except that cast or forged end flanges attached by full penetration butt-welding may be used when approved by the purchaser. When a flange is attached by welding, the welding operator and welding procedure shall be qualified in accordance with ASME *BPVC* Section IX. The weld quality shall meet the examination acceptance standards requirements of ASME B31.3 or ISO 15649 as specified for normal fluid service.<sup>7</sup>

**5.4.4.3** Alignment rings (centering backing rings), integral or loose, used to facilitate welding shall be completely removed after welding. The end flanges or bonnet flanges and attachment weld shall have no internal tapers, nor other internal discontinuities, where the taper exceeds a four-to-one ratio in the axial to radial directions.

**5.4.4.4** The final wall thickness of the flange attachment weld shall not be less than that required for the body per Table 5.

**5.4.4.5** Heat treatment following welding, to ensure that the valve body and flange materials are suitable for the full range of service conditions, shall be performed as required by Table A.4, unless otherwise specified by the purchaser.

**5.4.4.6** The finished weld shall be free of cracks and shall show no indication of lack of fusion or incomplete penetration. The finished weld shall be ground, or otherwise finished to provide a smoothly contoured surface, and have a surface finish of  $R_a \leq 500 \mu\text{in.}$  ( $R_a \leq 12.5 \mu\text{m.}$ ).

**5.4.4.7** Face-to-face dimensions for flanged end valves, Class 150, Class 300, and Class 600, shall be in accordance with either ASME B16.10 or ISO 5752—Basic Series 3, Series 4, and Series 5 for gate valves; and Series 5 and Series 10 for Class 150 and Class 600 globe and check valves. Face-to-face dimensions for Class 1500 valves shall be in accordance with ASME B16.10.

#### 5.4.5 Butt-welding Ends

**5.4.5.1** Unless otherwise specified by the purchaser, butt-welding ends shall be in accordance with ASME B16.25 Figure 2(a) and Figure 3(a) for Welding End Detail for Joint Without Backing Ring and Table 7. The inside and outside surfaces of valve welding ends shall be machine-finished overall. The contour within the envelope is at the option of the manufacturer unless specifically ordered otherwise. Intersections should be slightly rounded. For nominal outside diameters and wall thickness of standard steel pipe, see ASME B36.10 and B36.19.

**5.4.5.2** End-to-end dimensions for butt-welding end valves, with either integral or fabricated stub ends, shall be in accordance with ASME B16.10 except that Class 800 shall be established by the manufacturer.

**5.4.5.3** For welding stub ends to a valve body, the welding qualifications, heat treatment, and examination requirements shall be in accordance with 5.4.4.2.

<sup>6</sup> The inertia welding process was originally approved under Code Case 1609 of the ASME *BPVC*. These requirements have been refined and incorporated into ASME *BPVC* Section IX. QW 262, *Inertia and Continuous Drive Friction Welding*, and QW 362, *Electron Beam Welding (EBW), Laser Beam Welding (LBW), and Friction Welding (FRW)*, cover welding variables for the inertia welding specification (WPS) and welding operator qualifications.

<sup>7</sup> Normal fluid service is one of several application categories specified in the ISO 15649 by reference to the ASME B31.3 piping code.

**Table 7—Butt-welding End Diameters**

DN (NPS) <sup>2</sup>	<i>A</i> <sup>1</sup> mm (in.)
8 (1/4)	13.7 (0.540)
10 (3/8)	17.1 (0.675)
15 (1/2)	21.3 (0.840)
20 (3/4)	26.7 (1.050)
25 (1)	33.4 (1.315)
32 (1 1/4)	42.2 (1.660)
40 (1 1/2)	48.3 (1.900)
50 (2)	60.3 (2.375)
65 (2 1/2)	73.0 (2.875)
80 (3)	88.9 (3.500)
100 (4)	(4.500)

1) The tolerance for diameter *A* (nominal outside diameter of the welding end) shall be  $\pm 0.8$  mm ( $\pm 0.031$  in.) for DN < 40 (NPS < 1 1/2) and  $+2.5/-0.8$  mm ( $\pm 0.10/-0.031$  in.) for DN  $\geq$  40 (NPS  $\geq$  1 1/2).

2) The tolerance for diameter B (nominal inside diameter of the pipe) shall be  $\pm 0.8$  mm ( $\pm 0.031$  in.)

#### 5.4.6 Body Seats

**5.4.6.1** Integral seats with overlays per Table 12 (CN) are permitted. Integral body seats (without overlays) are permitted in austenitic stainless steel and other Group 2 and Group 3 material bodies. An austenitic stainless steel or a hard facing material may be weld-deposited either directly on a valve body or on a separate body seat ring.

For valve seats where the hard facing is applied by a plasma arc or a laser process, seating surfaces shall have a minimum finished facing material thickness of 0.5 mm (0.020 in.). All other weld-deposited seating surfaces shall have a minimum finished facing material thickness of 1 mm (0.039 in.).

Body seating surfaces shall not have sharp corners, e.g. corners with an edge disposed to cause damage in conjunction with gate or disc seating surfaces at either the inner or outer seat circumference.

**5.4.6.2** Where separate seat rings are provided, they shall be threaded, rolled or pressed in place. For globe and lift-type check valves, rolled or pressed in place seat rings shall be seal welded. Sealing compounds or greases shall not be used when assembling seat rings, however, a light lubricant having a viscosity no greater than kerosene may be used to prevent galling when assembling mating surfaces.

#### 5.5 Valve Bonnet or Cover

**5.5.1** The bonnet of a gate or globe valve or the cover of a check valve shall be secured to the body, by one of the following methods:

- bolting;
- welding;
- threaded with a seal weld;
- threaded union nut, provided the valve is of Class  $\leq$  800.

**5.5.2** Gasketed joints shall be of a design that confines the gasket and prevents its over-compression. At assembly, all gasket contact surfaces shall be free of heavy oils, grease and sealing compounds. A light coating of lubricant, no heavier than kerosene, may be applied if needed to assist in proper gasket assembly.

**5.5.3** Unless otherwise specified in the purchase order, bonnet gaskets shall be spiral wound type with 18-8 stainless steel or nickel alloy windings and flexible graphite filler suitable for a valve operating temperature range of  $-29\text{ }^{\circ}\text{C}$  to  $540\text{ }^{\circ}\text{C}$  ( $-20\text{ }^{\circ}\text{F}$  to  $1000\text{ }^{\circ}\text{F}$ ).

**5.5.4** Bonnet and body flange bolting bearing surfaces shall be parallel to the flange face within  $1^{\circ}$ . Spot facing or back facing required to meet this requirement shall be in accordance with ASME B16.5.

**5.5.5** A bonnet or cover bolted to the body shall be secured by a minimum of four cap screws, studs or stud bolts. Internal socket head cap screws shall not be used. The minimum bolt size permitted is M10 or  $3/8$  in. Standard inch series bolting threads in accordance with Class 2A (external) or Class 2B (internal) of ASME B1.1 shall be used except if the purchaser specifies metric series bolting. When metric threads are used they shall meet Class 6H (internal) or Class 6g (external) of ASME B1.13M.

**5.5.6** Bolted bonnet and bolted cover joints, and threaded bonnet or threaded cover joints shall be in accordance with the requirements for Valve Joints in ASME B16.34.

**5.5.7** Bonnets without threads welded directly to valve bodies, shall be secured by a full strength weld having two or more welding passes (layers), unless otherwise specified by the purchaser. The thickness of the deposited weld shall be not less than the required wall thickness of the valve body per the requirements of Table 5. The weld quality shall meet the examination acceptance standards requirements of ASME B31.3 or ISO 15649 as specified for normal fluid service.<sup>8</sup> Body bonnet joints of the threaded and seal welded design shall be secured by seal welding in accordance with ASME B31.3 and cover all exposed threads.

**5.5.8** The welding operator and welding procedure qualifications, heat treatment and examination requirements shall be in accordance with 5.4.4.2. Bonnet to body full strength welds and seal welds shall be postweld heat treated in accordance with Table A.4, except that:

- a) seal welds of P4, P5A, and P5B materials<sup>9</sup> are exempt from post weld heat treatment when a weld procedure is used that provides a weld hardness in accordance with ASME B31.3, Table 331.1.1; and
- b) solution annealing of austenitic stainless steel welds is not required.

## **5.6 Closure Element**

### **5.6.1 Seating Surfaces**

Wedge, disc or closure element seating surfaces shall be integral or have a facing of weld metal. Weld-deposited seating surfaces shall have a minimum finished facing material thickness of 1 mm (0.039 in.). A wedge, disc, or closure element of solid metal equal to the trim material (CN) is permitted (see 6.1.4).

### **5.6.2 Gate Valve Wedges**

**5.6.2.1** Gate valves shall be provided with a one-piece wedge gate that clears the body seat opening when the valve is in the full-open position. The installed wedge gate outer seating surfaces shall be free of sharp edges so as not to score or gouge the body seating surfaces during opening or closing.

<sup>8</sup> Normal fluid service is one of several application categories specified in the ISO 15649 by reference to the ASME B31.3 piping code.

<sup>9</sup> For materials designated P4, P5A, and P5B, see ASME B31.3 or ISO 15649.



**5.6.2.2** A slot near the top of the wedge gate shall be provided to receive the button or tee-head stem connection. The wedge gate shall be guided in the body in a manner that prevents rotation and leads the gate re-entry between the seats.

**5.6.2.3** The wedge gate shall be designed to account for seat wear. The dimensions that fix the position of the wedge gate seats relative to the body seats shall be such that the wedge gate, starting from the time when the valve is new, can move into the seats, should the seats wear, a distance defined as wear travel. Wear travel is in a direction parallel with the valve stem. The required minimum wear travel,  $h_w$ , varies with valve size in accordance with Table 8.

**Table 8—Wear Travel for Gate Valves**

DN	Minimum Wear Travel Distance $h_w$ mm (in.)	NPS
$8 \leq DN \leq 20$	1 (0.039)	$1/4 \leq NPS \leq 3/4$
$25 \leq DN \leq 32$	1.5 (0.06)	$1 \leq NPS \leq 1 1/4$
$40 \leq DN \leq 65$	2 (0.08)	$1 1/2 \leq NPS \leq 2 1/2$
$80 \leq DN \leq 100$	3 (0.12)	$3 \leq NPS \leq 4$

### 5.6.3 Globe Valve Disc

**5.6.3.1** Globe valves shall be provided with discs that are non-integral with the stem. The disc shall have a conical (plug) seating face or, when specified by the purchaser, a flat seating face.

**5.6.3.2** When assembled, the globe valve disc-to-stem retaining design shall be such that the disc cannot become detached from the stem as a result of flow-induced vibrations or attached piping movement. The means of disc-to-stem retention shall be of a design that allows the disc to align with the valve seat.

### 5.6.4 Check Valve Closure Element

**5.6.4.1** Check valves shall be provided with piston, ball or swing type closure elements.

**5.6.4.2** Piston type and ball type check valve closure elements shall be guided over the full length of their travel. The guide and closure element combination shall be designed so that a damping of the movement occurs towards the top end of the closure element travel.

**5.6.4.3** Piston check and ball check valves shall be designed so that, when in the fully opened position, the net flow area between the closure element and the body seat is greater than or equal to that of the seat opening corresponding to the seat diameter shown in Table 1.

**5.6.4.4** For swing check valves, disc-to-hinge retaining nuts shall be positively secured by mechanical means.

## 5.7 Stem

**5.7.1** Stem design shall be outside screw and yoke (OS&Y), except where inside screw (ISRS) is specified. Stems with inside screw shall be limited to gate and globe valves having pressure designation Class  $\leq 800$  in the nominal size range  $8 \leq DN \leq 65$  ( $1/4 \leq NPS \leq 2 1/2$ ).

**5.7.2** The minimum stem diameter,  $d_s$ , measured where the stem section passes through the packing, shall be in accordance with Table 9 for standard bore gate and globe valves and Table 10 for full bore gate and globe valves.

Table 9—Minimum Stem Diameter for Standard Bore Valves

DN	Minimum Stem Diameter, $d_s$ mm (in.)			NPS
	Class 150, Class 300, Class 600, Class 800	Class 1500		
		Gate or Globe Valves	Gate Valves	
8	7.0 ( $9/32$ )	10.0 ( $13/32$ )	10.0 ( $13/32$ )	$1/4$
10	7.0 ( $9/32$ )	10.0 ( $13/32$ )	10.0 ( $13/32$ )	$3/8$
15	8.5 ( $11/32$ )	10.0 ( $13/32$ )	10.0 ( $13/32$ )	$1/2$
20	9.5 ( $3/8$ )	11.0 ( $7/16$ )	11.0 ( $7/16$ )	$3/4$
25	11.0 ( $7/16$ )	14.0 ( $9/16$ )	14.0 ( $9/16$ )	1
32	12.5 ( $1/2$ )	15.5 ( $5/8$ )	15.5 ( $5/8$ )	$1\frac{1}{4}$
40	14.0 ( $9/16$ )	15.5 ( $5/8$ )	15.5 ( $5/8$ )	$1\frac{1}{2}$
50	15.5 ( $5/8$ )	16.5 ( $21/32$ )	16.5 ( $21/32$ )	2
65	17.5 ( $11/16$ )	19.0 ( $3/4$ )	—	$2\frac{1}{2}$
80	19.0 ( $3/4$ )	25.0 (1)	—	3
100	22.0 ( $7/8$ )	28.5 ( $1\frac{1}{8}$ )	—	4

Table 10—Minimum Stem Diameter for Full-bore Valves

DN	Minimum Stem Diameter, $d_s$ mm (in.)			NPS
	Class 150, Class 300, Class 600, Class 800	Class 1500		
		Gate or Globe Valves	Gate Valves	
8	7.0 ( $9/32$ )	10 ( $13/32$ )	10 ( $13/32$ )	$1/4$
10	8.5 ( $11/32$ )	10 ( $13/32$ )	10 ( $13/32$ )	$3/8$
15	9.5 ( $3/8$ )	11.0 ( $7/16$ )	11.0 ( $7/16$ )	$1/2$
20	11.0 ( $7/16$ )	14.0 ( $9/16$ )	14.0 ( $9/16$ )	$3/4$
25	12.5 ( $1/2$ )	15.5 ( $5/8$ )	15.5 ( $5/8$ )	1
32	14.0 ( $9/16$ )	15.5 ( $5/8$ )	15.5 ( $5/8$ )	$1\frac{1}{4}$
40	15.5 ( $5/8$ )	16.5 ( $21/32$ )	16.5 ( $21/32$ )	$1\frac{1}{2}$
50	17.5 ( $11/16$ )	19.0 ( $3/4$ )	—	2
65	19.0 ( $3/4$ )	25.0 (1)	—	$2\frac{1}{2}$
80	22.0 ( $7/8$ )	28.5 ( $1\frac{1}{8}$ )	—	3
100	25.0(1)	28.5 ( $1\frac{1}{8}$ )	—	4

**5.7.3** The stem shall be one-piece wrought material. Stems fabricated by welding are not permitted. The stem surface that passes through the packing shall have a surface finish value of  $Ra \leq 0.80 \mu\text{m}$  (32  $\mu\text{in.}$ )

**5.7.4** The stem threads shall be of trapezoidal form in accordance with ASME B1.5 and ASME B1.8, with nominal dimensional variations allowed. Stem threads shall be such that a direct-operated handwheel rotated in a clockwise direction will close the valve. The major diameter of the stem threads shall not be less than 1.5 mm (0.059 in.) below that of the actual stem diameter (see 5.7.2).

**5.7.5** The means of stem-to-wedge/disc attachment shall be designed so as to prevent the stem from becoming disengaged from the wedge/disc while the valve is in service. For attachment to the wedge/disc, the stem shall have an integral tee for outside stem thread gate valves and an integral cylindrical button for inside stem thread gate valves and for all globe valves. Threaded or pinned stem attachment means shall not be used.

**5.7.6** Valve stems, except those used in globe valves where the backseat function is with a disc component, shall include a conical or spherical raised surface that will seat against the bonnet backseat when the wedge/disc is at its full open position. A back seating arrangement is a requirement for all gate and globe valves and, as such, is not meant to imply a manufacturer's recommendation for its use for the purpose of adding or replacing packing while the valve is under pressure.

**5.7.7** Gate valve stem design shall be such that, for valves with outside screw stems, the strength of the stem-to-wedge gate connection and the part of the stem within the valve pressure boundary shall, under axial load, exceed the strength of the stem at the root of the operating thread. For both outside and inside screw valves, the design of the stem, wedge gate and stem connection to the wedge gate shall be such that, were mechanical failure to occur, it would do so at a stem section outside the valve pressure boundary.

**5.7.8** Globe valve stem thrust point against the disc shall be rounded.

## **5.8 Stem Nut or Stem Bushing**

**5.8.1** The internal thread in the stem nut (yoke sleeve or stem bushing) shall be of trapezoidal form in accordance with ASME B1.5 and ASME B1.8 with nominal dimensional variations permitted.

**5.8.2** The fixed stem nut used in globe valves shall be threaded or otherwise fitted onto the yoke and positively locked in position.

## **5.9 Packing, Packing Chamber, and Gland**

**5.9.1** The minimum uncompressed total height of the installed packing  $h_p$ , shall be in accordance with Table 11. The packing height values in Table 11 are directly related to the stem diameters shown in Table 9 and Table 10. When a stem diameter greater than that of Table 9 and Table 10 is used, the manufacturer shall determine if the uncompressed packing height needs to be increased.

**5.9.2** The packing chamber bore shall have a surface finish,  $Ra$  of  $3.2 \mu\text{m}$  (125  $\mu\text{in.}$ ) or smoother. The bottom of the packing chamber shall be flat.

**5.9.3** A gland shall be provided for packing compression. The gland may be either a self-aligning gland or an integral part of the gland flange. The outer end of a separate gland shall have a lip whose outer diameter exceeds the diameter of the packing chamber bore so as to block its entry into the bore.

**5.9.4** Valves shall be qualified by type testing to meet the fugitive emissions requirements of API 624.

**Table 11—Minimum Uncompressed Packing Height**

DN	Minimum Uncompressed Packing Height, $h_p$ mm (in.)		NPS
	Class 150, Class 300, Class 600, Class 800	Class 1500	
8	16 (0.63)	16 (0.63)	1/4
10	16 (0.63)	16 (0.63)	3/8
15	16 (0.63)	16 (0.63)	1/2
20	16 (0.63)	16 (0.63)	3/4
25	16 (0.63)	24 (0.94)	1
32	24 (0.94)	32 (1.25)	1 1/4
40	24 (0.94)	32 (1.25)	1 1/2
50	24 (0.94)	32 (1.25)	2
65	24 (0.94)	32 (1.25)	2 1/2
80	32 (1.25)	40 (1.56)	3
100	32 (1.25)	40 (1.56)	4

## 5.10 Packing Retention

**5.10.1** Packing and packing gland retention for valves with outside screw stems shall be by bolting through two holes in a gland flange that is either separate from, or integral to, the gland. Open gland flange bolt slots shall not be used.

**5.10.2** Gland flange bolts shall be hinged eyebolts, headed bolts, stud bolts, or studs. Hexagon nuts shall be used.

**5.10.3** The gland bolting for gate and globe valves shall not be anchored to the bonnet or yoke through a fillet welded attachment or stud welded pins.

**5.10.4** Packing and packing gland retention for valves with inside screw stems shall be by a packing nut threaded directly onto the valve bonnet or in accordance with 5.10.1, 5.10.2, and 5.10.3.

## 5.11 Handwheel

**5.11.1** Gate and globe valves shall be supplied with direct operated handwheels that close the valve when turned in a clockwise direction.

**5.11.2** The handwheel shall be a spoke and rim design.

**5.11.3** The handwheel shall be secured to the stem or stem nut by a threaded handwheel nut.

## 6 Materials

### 6.1 Trim Materials

**6.1.1** Trim items include the stem, the wedge/disc seat surfaces and the body or seat ring seat surfaces. The valve trim for check valves shall consist of the seating surface of the closure element and body or seat ring. The trim combination number (CN) identifies both the stem material and the associated seating surface material. Except as

noted in 6.1.2 and 6.1.3 or when otherwise agreed between the purchaser and manufacturer, the trim material combinations shall be in accordance with Table 12.

**6.1.2** Trims of free machining materials, e.g. 13Cr steel grades containing additions of elements such as lead, selenium or sulfur to enhance machinability, are intentionally not listed in Table 12. They may be used only when specified by the purchaser, in which case they shall be identified by the appropriate trim number from Table 12 plus 100. The affected trim CN numbers would thus be identified as, e.g. CN 101, 104, 105, 106, 107, and 108. Correspondingly, hardfacing or other material overlays shall not be applied to free machining grades of base materials unless so specified by the purchaser.

**Table 12—Nominal Seating Surfaces, Stem, or Weld-Deposited Materials and Hardness**

Trim Number (CN)	Nominal Trim	Seat Surface Hardness (HB) Minimum <sup>a</sup>	Seat Surface Material Type <sup>b</sup>	Seat Surface Typical Specifications Grade			Stem		
				Cast	Forged	Welded <sup>m</sup>	Material Type <sup>b</sup>	Typical Specifications Type	Stem Hardness (HB)
3	F310	Note <sup>d</sup>	25Cr-20Ni	NA	A182 (F310)	AWS A5.9 ER310	25Cr-20Ni	A276-T310	Note <sup>d</sup>
4	Hard F6	750 <sup>e</sup>	Hard 13Cr	NA	Note <sup>f</sup>	NA	13Cr	A276-T410 or T420	200 min 275 max
5	Hardfaced	350 <sup>e</sup>	Co-Cr A <sup>g</sup>	NA	NA	AWS A5.13 E or R CoCrA	13Cr	A276 T410 or T420	200 min 275 max
5A	Hardfaced	350 <sup>e</sup>	Ni-Cr	NA	NA	Note <sup>h</sup>	13Cr	A276 T410 or T420	200 min 275 max
6	F6 and Cu-Ni	250 <sup>i</sup>	13Cr and Cu-Ni	A 217 (CA 15)	A182 (F6a)	AWS A5.9 ER410	13Cr NA	A276 T410 or T420 NA	200 min
		175 <sup>i</sup>		NA	Note <sup>k</sup>	NA			NA
7	F6 and Hard F6	250 <sup>i</sup>	13Cr and Hard 13Cr	A 217 (CA 15)	A182 (F6a)	AWS A5.9 ER410	13Cr NA	A276 T410 or T420 NA	200 min
		750 <sup>i</sup>		NA	Note <sup>f</sup>	NA			NA
8	F6 and Hardfaced	250 <sup>i</sup>	13Cr and Co-Cr A <sup>g</sup>	A 217 (CA 15)	A182 (F6a)	AWS A5.9 ER410	NA	A276 T410 or T420 NA	200 min
		350 <sup>i</sup>		NA	NA	AWS A5.13 E or R CoCrA			NA
8A	F6 and Hardfaced	250 <sup>i</sup> 350 <sup>i</sup>	13Cr and Ni-Cr	A 217 (CA 15) NA	A182 (F6a) NA	AWS A5.9 ER410 Note <sup>h</sup>	13Cr NA	A276 T410 or T420 NA	200 min 275 max NA
9	Monel	Note <sup>d</sup>	Ni-Cu Alloy	NA	MFG Standard	NA	Ni-Cu Alloy	MFG Standard	Note <sup>d</sup>
10	316	Note <sup>d</sup>	18Cr-8Ni	A351 (CF8M)	A183 (F316)	AWS A5.9 ER316	18Cr-8Ni-Mo	A276-T316	Note <sup>d</sup>
11	Monel and Hardfaced	Note <sup>d</sup> 350 <sup>i</sup>	Ni-Cu Alloy and Trim 5 or 5A	NA	MFG Standard	NA See Trim 5 or 5A	Ni-Cu Alloy NA	MFG Standard NA	Note <sup>d</sup> NA
12	316 and Hardfaced	Note <sup>d</sup>	18Cr-8Ni-Mo Trim 5 or 5A	A351 (CF8M)	A182 (F316)	AWS A5.9 ER316	18Cr-8Ni-Mo NA	A276-T316 NA	Note <sup>d</sup>
		350 <sup>i</sup>		NA	NA	See Trim 5 or 5A			NA
13	Alloy 20	Note <sup>d</sup>	19Cr-29Ni	A351 (CN7M)	B473	AWS A5.9 ER320	19Cr-29Ni	B473	Note <sup>d</sup>

**Table 12—Nominal Seating Surfaces, Stem, or Weld-Deposited Materials and Hardness (Continued)**

Trim Number (CN)	Nominal Trim	Seat Surface Hardness (HB) Minimum <sup>a</sup>	Seat Surface Material Type <sup>b</sup>	Seat Surface Typical Specifications Grade			Stem		
				Cast	Forged	Welded <sup>m</sup>	Material Type <sup>b</sup>	Typical Specifications Type	Stem Hardness (HB)
14	Alloy 20 and Hardfaced	Note <sup>d</sup> 350 <sup>i</sup>	19Cr-29Ni and Trim 5 or 5A	A351 (CN7M) NA	B473 NA	AWS A5.9 ER320 See Trim 5 or 5A	19Cr-29Ni NA	B473 NA	Note <sup>d</sup> NA
15	Hardfaced	350 <sup>e</sup>	Co-Cr A <sup>g</sup>	NA	NA	AWS 5.13 ECoCr-A	18Cr-8Ni	A276-T304	Note <sup>d</sup>
16	Hardfaced	350 <sup>e</sup>	Co-Cr A <sup>g</sup>	NA	NA	AWS 5.13 ECoCr-A	18Cr-8Ni-Mo	A276-T316	Note <sup>d</sup>
17	Hardfaced	350 <sup>e</sup>	Co-Cr A <sup>g</sup>	NA	NA	AWS 5.13 ECoCr-A	18Cr-10Ni-Cb	A276-T347	Note <sup>d</sup>
18	Hardfaced	350 <sup>e</sup>	Co-Cr A <sup>g</sup>	NA	NA	AWS 5.13 ECoCr-A	19Cr-29Ni	B473	Note <sup>d</sup>
19	Nickel <sup>o</sup>	Note <sup>d</sup>	Ni Alloy	MFG Standard <sup>o</sup>	MFG Standard <sup>o</sup>	MFG Standard	Ni Alloy <sup>o</sup>	MFG Standard <sup>o</sup>	Note <sup>d</sup>
20	Nickel <sup>o</sup> and Hardfaced	Note <sup>d</sup>	Ni Alloy	MFG Standard <sup>o</sup>	MFG Standard <sup>o</sup>	-	Ni Alloy <sup>o</sup>	MFG Standard <sup>o</sup>	Note <sup>d</sup>
		350 <sup>i</sup>	Co-Cr-A <sup>g</sup>	-	-	AWS 5.13 ECoCr-A AWS 5.21 ERCr-A	-	-	Note <sup>d</sup>
21	Hardfaced <sup>o</sup>	350 <sup>e</sup>	Co-Cr-A <sup>g</sup>	-	-	AWS 5.13 ECoCr-A AWS 5.21 ERCr-A	Ni Alloy <sup>o</sup>	MFG Standard <sup>o</sup>	Note <sup>d</sup>

NOTE Cr = Chromium; Ni = Nickel; Co = Cobalt; Cu = Copper; NA = Not Applicable.

<sup>a</sup> HB (formerly BHN) is the symbol for the Brinell hardness per ASTM E10.

<sup>b</sup> Free machining grades of 13Cr are prohibited.

<sup>c</sup> Body and closure element seat surfaces should be 250 HB minimum with a 50 HB minimum differential between the body and closure element seat surfaces.

<sup>d</sup> Manufacturer's standard hardness.

<sup>e</sup> Differential hardness between the body and closure element seat surfaces is not required.

<sup>f</sup> Case hardness by nitriding to a thickness of 0.13 mm (0.005 in.) minimum.

<sup>g</sup> This classification includes such trademark materials as Stellite 6™ \*, Stody 6™ \* and Wallex 6™ \*, the use of CoCr-E (Stellite 21™ \*) or equal is an acceptable substitution for CoCr-A in globe and check valves.

<sup>h</sup> Manufacturer's standard hardfacing with a maximum iron content of 25 %.

<sup>i</sup> Hardness differential between the body and closure element seat surfaces shall be the manufacturer's standard.

<sup>j</sup> Not used.

<sup>k</sup> Manufacturer's standard with 30 Ni minimum.

<sup>l</sup> Not used.

<sup>m</sup> Not used.

<sup>n</sup> Not used.

<sup>o</sup> Trim materials, including stem and base material for HF trim items, shall have a corrosion resistance, and temperature limit at least equal to the valve body's corrosion resistance and pressure temperature rating.

\* This term is used as an example only, and does not constitute an endorsement of this product by API.

**6.1.3** The trim material shall correspond to a listed CN taking account of the recommendations of Annex G, except that an alternative CN may be furnished in accordance with Table 13. When an alternative CN from Table 13 is specified by a purchaser, the corresponding Table 13 Specified CN shall not be substituted.

**6.1.4** The base material of the valve wedge/disc/closure element and separate body seat ring, when used, shall be of a nominal material composition equal to the body or to that of the stem material; except for wedge or disc or closure element material made of solid trim material as allowed by 5.6.1.

**Table 13—Alternative CNs**

Specified CN	Alternative CN
8	5
10	12 or 16
12	16
13	14
15	16
19	20 or 21
20	21

## 6.2 Materials Other Than Trim

**6.2.1** Materials for valve parts other than trim items shall be in accordance with Table 14.

**6.2.2** Defects in the cast or forged valve pressure shell materials revealed during manufacturing operations or testing may be repaired as permitted by the most nearly applicable specification for forgings or castings. All repair welding shall be in accordance with a written procedure. Filler rods used for repairs shall be such as to produce a repair weld having characteristics similar to the parent metal. Repairs shall be heat treated after repair welding in accordance with the material specification.

## 6.3 Compliance

When specified in the purchase order, shell, trim and bolting materials shall comply with NACE MR 0103.

## 7 Marking

### 7.1 Legibility

Each valve identified as being in accordance with this standard shall be clearly marked as such on the body and/or on an identification plate in accordance ASME B16.34 and the following. In the event of conflict, the requirements of the present clause shall apply.

### 7.2 Body Marking

**7.2.1** Valve bodies shall be marked with the following information:

- manufacturer's name or trademark;
- body material identification;
- pressure class designation number (e.g. Class 1500);

**Table 14—Materials for Valve Parts Other Than Trim Items**

Part	Material
Body and bonnet <sup>a b c</sup>	A forging, forged bar or casting material as selected from ASME B16.34, Group 1, 2 or Group 3 and listed in Table 1.
Cover plate <sup>a b c</sup>	A forging, forged bar, or casting material as selected from ASME B16.34, Group 1, 2 or Group 3 and listed in Table 1 may also be used. Plate material listed in ASME B16.34, Table 1 may also be used for check valve covers.
Bonnet extension and union nut <sup>c</sup>	A material of the same nominal composition as the bonnet as selected from the list of material from which the body was selected.
Bellows	See B.6.
Bellows fittings	Attachment rings and other bellows fittings shall be of materials suitable for attachment welding of the bellows to the valve body, bonnet or stem as applicable.
Wedge/disc	The base material of the wedge/disc shall be of a nominal material composition equal to the body material or the stem material (see 6.1.4).
Yoke, separate	Carbon steel, stainless steel or similar material composition as the bonnet.
Bolting: body-to-bonnet and body-to-cover	Unless other materials are agreed between the purchaser and manufacturer, refer to the recommended bolting material in Annex G.
Bolting: gland and yoke	Bolting materials of a Type 300 or Type 400 series stainless steel. Also, material at least equal to ASTM A307-Grade B may be used for yoke bolting.
Seat ring	The base material of the seat ring, when used, shall be of a nominal material composition equal to the body material or the stem material (see 6.1.4).
Gland flange	Steel.
Packing nut	To be of a material with a corrosion resistance at least equal to the body.
Gland	Material with a melting point above 1750 °F (955 °C).
Packing	Non-asbestos material suitable for steam and petroleum fluids over a temperature range of -29 °C to 540 °C (-20 °F to 1000 °F) and containing a corrosion inhibitor.
Gaskets	See 5.5.3.
Stem nut or stem bushing	Austenitic ductile iron, 13Cr steel, or copper alloy having a melting point above 955 °C (1750 °F).
Misc. internal parts (i.e. spring, hinge pin, disc nut)	Similar material composition as would be used for a valve stem, based on the valve trim requirement.
Handwheel	Malleable iron, carbon steel, or ductile iron.
Identification plate	A corrosion resistant metal.
<p><sup>a</sup> A preference for body and bonnet or cover material form (e.g. forging, forged bar, or casting) requires specification by the purchaser (see Annex F).</p> <p><sup>b</sup> For valve sizes DN ≤ 50 (NPS ≤ 2), the reference standard design specifies forging material for the body and bonnet, or cover (see 5.1).</p> <p><sup>c</sup> Bonnet nuts, welded, and threaded and seal welded bonnets, and bonnets of ISRS valves may be made from bar stock. The bar stock shall be listed and meet the requirements of Table 1, Group 1, Group 2, and Group 3 of ASME B16.34, including the notes, for the appropriate material group. Free machining material shall not be used.</p>	



- nominal size, as either, NPS number [e.g. 2 or the DN followed by the appropriate size number (e.g. DN 50)];
- an arrow on globe valve bodies to indicate the preferred direction for the installed valve;
- an arrow on check valve bodies to indicate required flow direction.

**7.2.2** For valves DN < 25 (NPS < 1), if the size or shape of the valve body precludes the inclusion of all the required markings, one or more may be omitted provided that they are shown on the identification plate. The sequence of omission shall be as follows:

- a) nominal size,
- b) pressure class designation,
- c) body material.

### **7.3 Ring Joint Groove Marking**

Body end flanges require special marking when the end flanges are grooved for ring type joint assembly. When so grooved, the ring joint gasket groove number, e.g. R25, shall be stamped on the rim of both end flanges. Ring joint gasket groove numbers are given in ASME B16.5.

### **7.4 Identification Plate Marking**

Each valve shall be provided with at least one identification plate. The identification plate marking, as applicable, shall include but is not limited to:

- the manufacturer's name;
- compliance marking ("API 602/ASME B16.34");
- pressure class designation (e.g. Class 800);
- manufacturer's identification number (e.g. catalog number);
- trim identification for the stem, seat, and closure element;
- maximum pressure at 100 °F (38 °C) using either psi units at 100 °F, bar units at 38 °C or MPa units at 38 °C;
- limiting temperature, if applicable;
- limiting pressure, if applicable; and
- any special use limitation.

### **7.5 Weld Fabrication Marking**

When extensions for stub ends, flanges, or extended body ends are welded to a valve or a valve body-to-bonnet is fabricated by welding or seal welding, the identification plate, the extension, body or bonnet shall be marked as follows.

- The letters "WLD".
- The material grade designation for the extension if other than that of the body (or bonnet) of the attachment.

- The postweld heat treatment employed using the following identification letters: “SR” when stress relieved, “SA” when solution annealed, “A” when annealed, “N” when normalized, “NT” when normalized and tempered, “QT” when quenched and tempered. When the aforementioned symbols do not apply symbols consistent with the specifications for the materials joined are to be used.

These identification markings shall be located so as to avoid confusion with other required markings.

## **8 Testing and Inspection**

### **8.1 Pressure Tests**

Each assembled valve shall be pressure tested in accordance with the requirements of API 598.

### **8.2 Inspection**

**8.2.1** The valve manufacturer shall examine each valve to assure compliance to this standard.

**8.2.2** If inspection by the purchaser is specified in the purchase order, inspection shall be in accordance with API 598. Examination by the manufacturer shall be as specified in API 598.

## **9 Preparation for Dispatch**

**9.1** After testing, the test fluid shall be drained from each valve in preparation for dispatch.

**9.2** Stem packing shall be in place and the remaining packing adjustment, with the gland tight, shall be greater than one packing width.

**9.3** Except for austenitic stainless steel valves, unmachined exterior valve body and bonnet surfaces shall have a rust-preventative coating.

**9.4** Except for austenitic stainless steel valves, machined or threaded surfaces shall be coated with an easily removable rust inhibitor.

**9.5** Protective covers or caps of wood, wood fiber, plastic, or metal shall be securely affixed to valve ends of flanged and butt-welding end valves in order to safeguard the gasket surfaces and weld end preparations. The cover design shall be such that the valve cannot be installed in a pipeline with the protective cover in place.

**9.6** Protective end plugs of wood, wood fiber, plastic or metal shall be securely inserted into the valve ends of socket welding and threaded end valves. The protective plug design shall be such that the valve cannot be installed in a pipeline with the plug in place.

**9.7** At the time of shipment, the wedge/disc of a gate or a globe valve shall be in the closed position.

**9.8** When special packaging is necessary, the purchaser shall specify the requirements in the purchase order.

## **10 Purchase Order Information**

Items marked with a bullet (●) in Annex F are considered an integral part of this standard, and shall be specified by the purchaser.

## **Annex A** (informative)

### **Use of API Monogram by Licensees**

#### **A.1 Scope**

The API Monogram® is a registered certification mark owned by the American Petroleum Institute (API) and authorized for licensing by the API Board of Directors. Through the API Monogram Program (<http://www.api.org/certification-programs/api-monogram-program-and-apiqr.aspx>), API licenses product manufacturers to apply the API Monogram to new products which comply with product specifications and have been manufactured under a quality management system that meets the requirements of API Q1. API maintains a complete, searchable list of all Monogram licensees on the API Composite List website ([www.api.org/compositelist](http://www.api.org/compositelist)).

The application of the API Monogram and license number on products constitutes a representation and warranty by the licensee to API and to purchasers of the products that, as of the date indicated, the products were manufactured under a quality management system conforming to the requirements of API Q1 and that the product conforms in every detail with the applicable standard(s) or product specification(s). API Monogram program licenses are issued only after an on-site audit has verified that an organization has implemented and continually maintained a quality management system that meets the requirements of API Q1 and that the resulting products satisfy the requirements of the applicable API product specification(s) and/or standard(s). Although any manufacturer may claim that its products meet API product requirements without monogramming them, only manufacturers with a license from API can apply the API Monogram to their products.

Together with the requirements of the API Monogram license agreement, this annex establishes the requirements for those organizations who wish to voluntarily obtain an API license to provide API monogrammed products that satisfy the requirements of the applicable API product specification(s) and/or standard(s) and API Monogram Program requirements.

For information on becoming an API Monogram Licensee, please contact API, Certification Programs, 1220 L Street, N. W., Washington, DC 20005 or call 202-682-8145 or by email at [certification@api.org](mailto:certification@api.org).

#### **A.2 Normative References**

API Specification Q1, *Specification for Quality Management System Requirements for Product Manufacturing for the Petroleum and Natural Gas Industry*

#### **A.3 Terms and Definitions**

For purposes of this annex, the following terms and definitions apply:

##### **A.3.1**

##### **API monogramable product**

Product that has been newly manufactured by an API licensee utilizing a fully implemented API Q1 compliant quality management system and that meets all the API specified requirements of the applicable API product specification(s) and/or standard(s).

##### **A.3.2**

##### **API specified requirements**

Requirements, including performance and licensee-specified requirements, set forth in API Q1 and the applicable API product specification(s) and or standard(s).

NOTE Licensee-specified requirements include those activities necessary to satisfy API specified requirements.

**A.3.3****API product specification**

Prescribed set of rules, conditions, or requirements attributed to a specified product which address the definition of terms; classification of components; delineation of procedures; specified dimensions; manufacturing criteria; material requirements, performance testing, design of activities; and the measurement of quality and quantity with respect to materials; products, processes, services, and/or practices.

**A.3.4****licensee**

Organization that has successfully completed the application and audit process and has been issued a license by API.

**A.3.5****design package**

Records and documents required to provide evidence that the applicable product has been designed in accordance with API Q1 and the requirements of the applicable product specification(s) and/or standard(s).

**A.4 Quality Management System Requirements**

An organization applying the API Monogram to products shall develop, maintain, and operate at all times a quality management system conforming to API Q1.

**A.5 Control of the Application and Removal of the API Monogram**

Each licensee shall control the application and removal of the API Monogram in accordance with the following:

- a) Products that do not conform to API specified requirements shall not bear the API Monogram.
- b) Each licensee shall develop and maintain an API Monogram marking procedure that documents the marking/monogramming requirements specified by this annex and any applicable API product specification(s) and/or standard(s). The marking procedure shall:
  - 1) define the authority responsible for application and removal of the API Monogram;
  - 2) define the method(s) used to apply the Monogram;
  - 3) identify the location on the product where the API Monogram is to be applied;
  - 4) require the application of the licensee's license number and date of manufacture of the product in conjunction with the use of the API Monogram;
  - 5) require that the date of manufacture, at a minimum, be two digits representing the month and two digits representing the year (e.g. 05-12 for May 2012) unless otherwise stipulated in the applicable API product specification(s) or standard(s); and
  - 6) require application of the additional API product specification(s) and/or standard(s) marking requirements.
- c) Only an API licensee may apply the API Monogram and its designated license number to API monogramable products.
- d) The API Monogram license, when issued, is site-specific and subsequently the API Monogram shall only be applied at that site specific licensed facility location.

- e) The API Monogram may be applied at any time appropriate during the production process but shall be removed in accordance with the licensee's API Monogram marking procedure if the product is subsequently found to be out of conformance with any of the requirements of the applicable API product specification(s) and/or standard(s) and API Monogram Program.

For certain manufacturing processes or types of products, alternative API Monogram marking procedures may be acceptable. Requirements for alternative API Monogram marking are detailed in the API Policy, API Monogram Program Alternative Marking of Products License Agreement, available on the API Monogram Program website at <http://www.api.org/alternative-marking>.

## **A.6 Design Package Requirements**

Each licensee and/or applicant for licensing must maintain a current design package for all of the applicable products that fall under the scope of each Monogram license. The design package information must provide objective evidence that the product design meets the requirements of the applicable and most current API product specification(s). The design package(s) must be made available during API audits of the facility.

In specific instances, the exclusion of design activities is allowed under the Monogram Program, as detailed in Advisory # 6, available on API Monogram Program website at <http://www.api.org/advisories>.

## **A.7 Manufacturing Capability**

The API Monogram Program is designed to identify facilities that have demonstrated the ability to manufacture equipment that conforms to API specifications and/or standards. API may refuse initial licensing or suspend current licensing based on a facility's level of manufacturing capability. If API determines that additional review is warranted, API may perform additional audits (at the organization's expense) of any subcontractors to ensure their compliance with the requirements of the applicable API product specification(s) and/or standard(s).

## **A.8 API Monogram Program: Nonconformance Reporting**

API solicits information on products that are found to be nonconforming with API specified requirements, as well as field failures (or malfunctions), which are judged to be caused by either specification deficiencies or nonconformities with API specified requirements. Customers are requested to report to API all problems with API monogrammed products. A nonconformance may be reported using the API Nonconformance Reporting System available at <http://compositelist.api.org/ncr.asp>.

## Annex B (normative)

### Requirements for Extended Body Valves

#### B.1 Scope

This annex specifies design, materials, fabrication, and examination requirements for gate and globe valve bodies to be used in valve assemblies identified as extended body valves. The valve body requirements stipulated in this annex, in combination with related gate and globe valve requirements in the body of this standard, constitute the requirements applicable to extended body valves. An extended valve body has one end fitted with either a conventional internal taper pipe thread connection or a conventional internal socket welding connection. The opposite body end is a prolongation, i.e. it is fitted with an extension that has an external end connection that is either an external taper pipe thread or an external weld end preparation.

#### B.2 Applicability

**B.2.1** Extensions with external taper pipe threads are designated only for Class 800 in nominal sizes  $20 \leq DN \leq 50$  ( $3/4 \leq NPS \leq 2$ ).

**B.2.2** Extensions with external weld end preparations are designated only for Class 800 and Class 1500 in nominal sizes  $15 \leq DN \leq 50$  ( $1/2 \leq NPS \leq 2$ ). Weld end preparations covered include both socket welding and butt-welding types.

**B.2.3** Internal socket welding ends or internal taper pipe thread ends are designated only for Class 800 and Class 1500 in nominal sizes  $15 \leq DN \leq 50$  ( $1/2 \leq NPS \leq 2$ ).

**B.2.4** Extended bodies covered by this standard are for valves whose end connections have the same nominal size for both the internal and the external ends, except that an extended valve body may be furnished with a DN 20 (NPS  $3/4$ ) external end and a DN 15 (NPS  $1/2$ ) internal end when the assembled valve otherwise meets all requirements for a DN 15 (NPS  $1/2$ ) valve.

#### B.3 Body Configuration

**B.3.1** The length of the extension or protrusion,  $L$ , required for an extended body, is the distance from the axis of the valve stem to the outer end of the extension's external end preparation. The maximum values for  $L$  are specified in Table B.1 and Table B.2. The minimum valve handwheel clearance, the distance between the outer end of the external end preparation, and the outer diameter of the valve handwheel, shall be 57 mm (2.25 in.).

**B.3.2** The minimum wall thickness and maximum length for extensions having threaded ends and the dimensions for threaded end preparations for Class 800 extended body valves shall be in accordance with Figure B.1 and Table B.1. The external end threads shall be in accordance with 5.4.3.2 and 5.4.3.3.

**B.3.3** The minimum wall thickness and maximum length for Class 800 and Class 1500 valve extensions having either socket welding or butt-welding ends and the dimensions for butt-welding end preparations for extended body valves shall be in accordance with Figure B.2 and Table B.2. The dimensions for socket welding end preparations shall be in accordance with Figure B.3 and Table B.3. The integral backing (centering) ring illustrated in Table B.2 for butt-welding ends is provided at the manufacturer's option. Its length shall not be included when measuring the required length of the extension.

**B.3.4** Integrally reinforced extensions, Figure B.2 a), shall have weld ends designed to meet the reinforcing requirements of ASME B31.3.

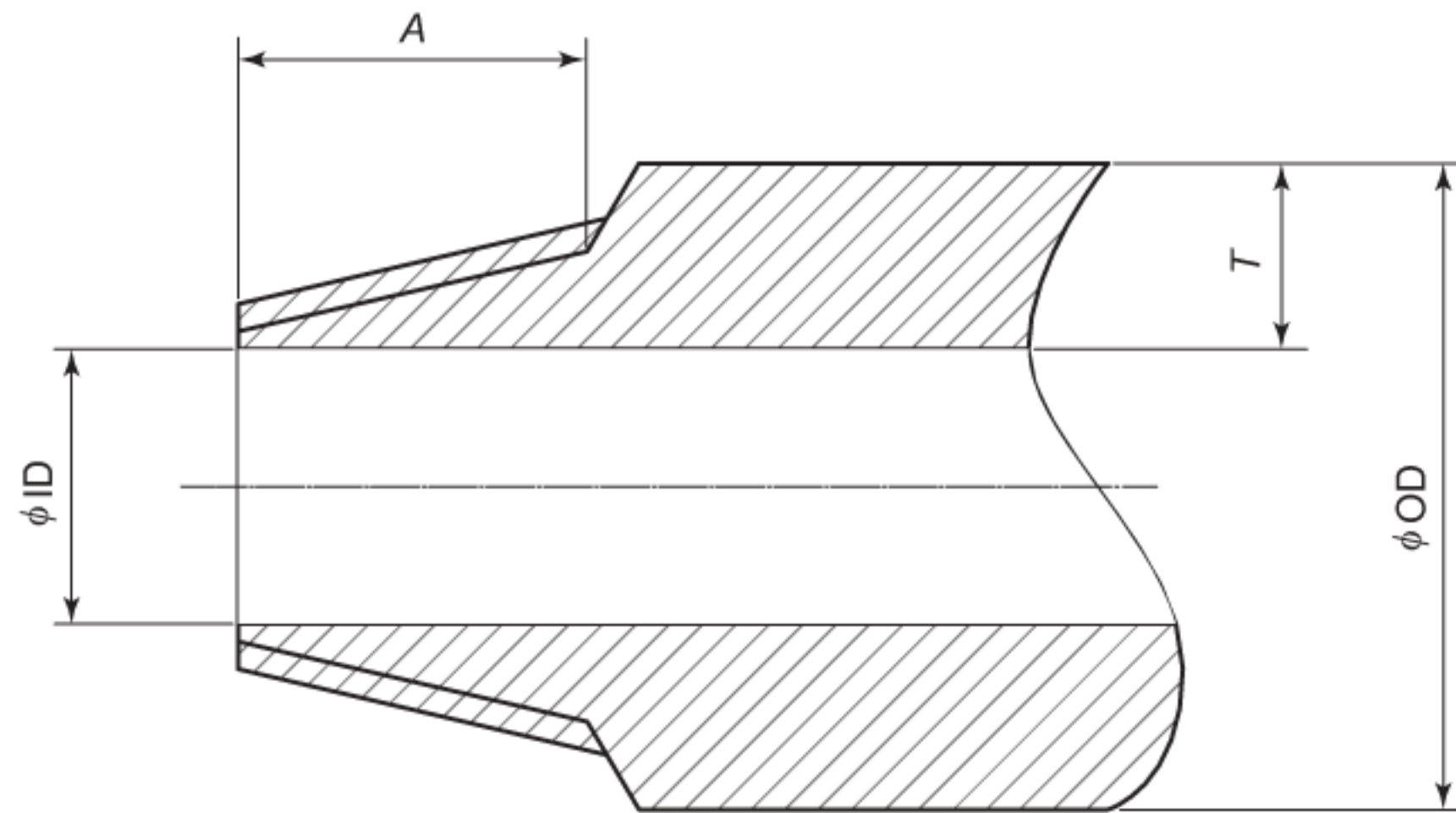
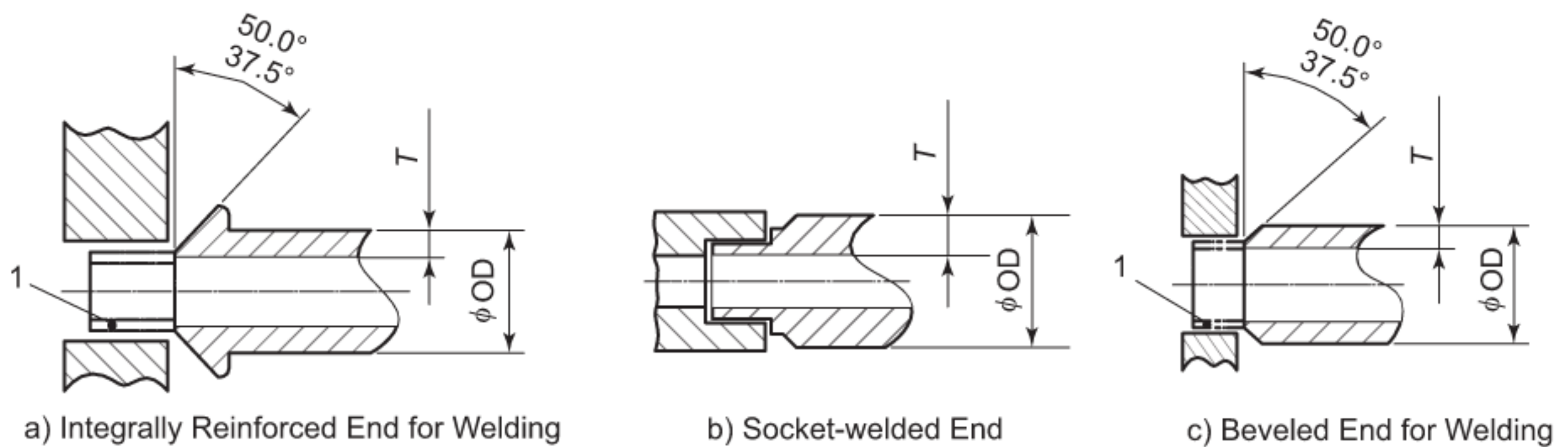

Figure B.1—Threaded End Extension for Class 800

Table B.1—Threaded End Extension for Class 800

DN	Maximum Length, <i>L</i> mm (in.)	Maximum Inside Diameter, ID mm (in.)	Minimum Outside Diameter, OD mm (in.)	Minimum Wall Thickness, <i>T</i> mm (in.)	Maximum Transition Length, <i>A</i> mm (in.)	NPS
20	115 (4.5)	16.5 (0.65)	25.9 (1.02)	4.8 (0.19)	23.4 (0.92)	3/4
25	180 (7.0)	21.3 (0.84)	32.5 (1.28)	5.6 (0.22)	28.2 (1.11)	1
40	230 (9.0)	38.1 (1.50)	47.5 (1.87)	6.1 (0.24)	29.2 (1.15)	1 1/2
50	255 (10.0)	47.5 (1.87)	59.4 (2.34)	7.1 (0.28)	30 (1.18)	2



**Key**

1 optional integral backing ring

Figure B.2—Welding End Extension for Class 800 and Class 1500

**Table B.2—Welding End Extension for Class 800 and Class 1500**

DN	Length of Welding End, $L$ mm (in.)		Minimum Outside Diameter, OD mm (in.)	Minimum Wall Thickness, $T$ mm (in.)		NPS
	Socket	Butt		Class 800	Class 1500	
15	$\leq 100$ ( $\leq 4.0$ )	$\leq 100$ ( $\leq 4.0$ )	23.1 (0.91)	5.5 (0.22)	5.6 (0.22)	1/2
15	$105 \leq L \leq 165$ (4.1 to 6.5)	$105 \leq L \leq 165$ (4.1 to 6.5)	26.9 (1.06)	6.3 (0.25)	6.3 (0.25)	1/2
15	—	$170 \leq L \leq 205$ (6.6 to 8.0)	31.7 (1.25)	6.3 (0.25)	6.3 (0.25)	1/2
20	$\leq 140$ ( $\leq 5.5$ )	$\leq 140$ ( $\leq 5.5$ )	25.9 (1.02)	4.8 (0.19)	6.1 (0.24)	3/4
20	$145 \leq L \leq 205$ (5.6 to 8.0)	$145 \leq L \leq 205$ (5.6 to 8.0)	31.7 (1.25)	7.5 (0.30)	7.5 (0.30)	3/4
25	$\leq 230$ ( $\leq 9.0$ )	$\leq 230$ ( $\leq 9.0$ )	32.5 (1.28)	5.6 (0.22)	7.1 (0.28)	1
40	$\leq 230$ ( $\leq 9.0$ )	$\leq 230$ ( $\leq 9.0$ )	47.5 (1.87)	6.2 (0.25)	9.7 (0.38)	1 1/2
50	$\leq 255$ ( $\leq 10.0$ )	$\leq 255$ ( $\leq 10.0$ )	59.4 (2.34)	7.6 (0.30)	11.9 (0.47)	2

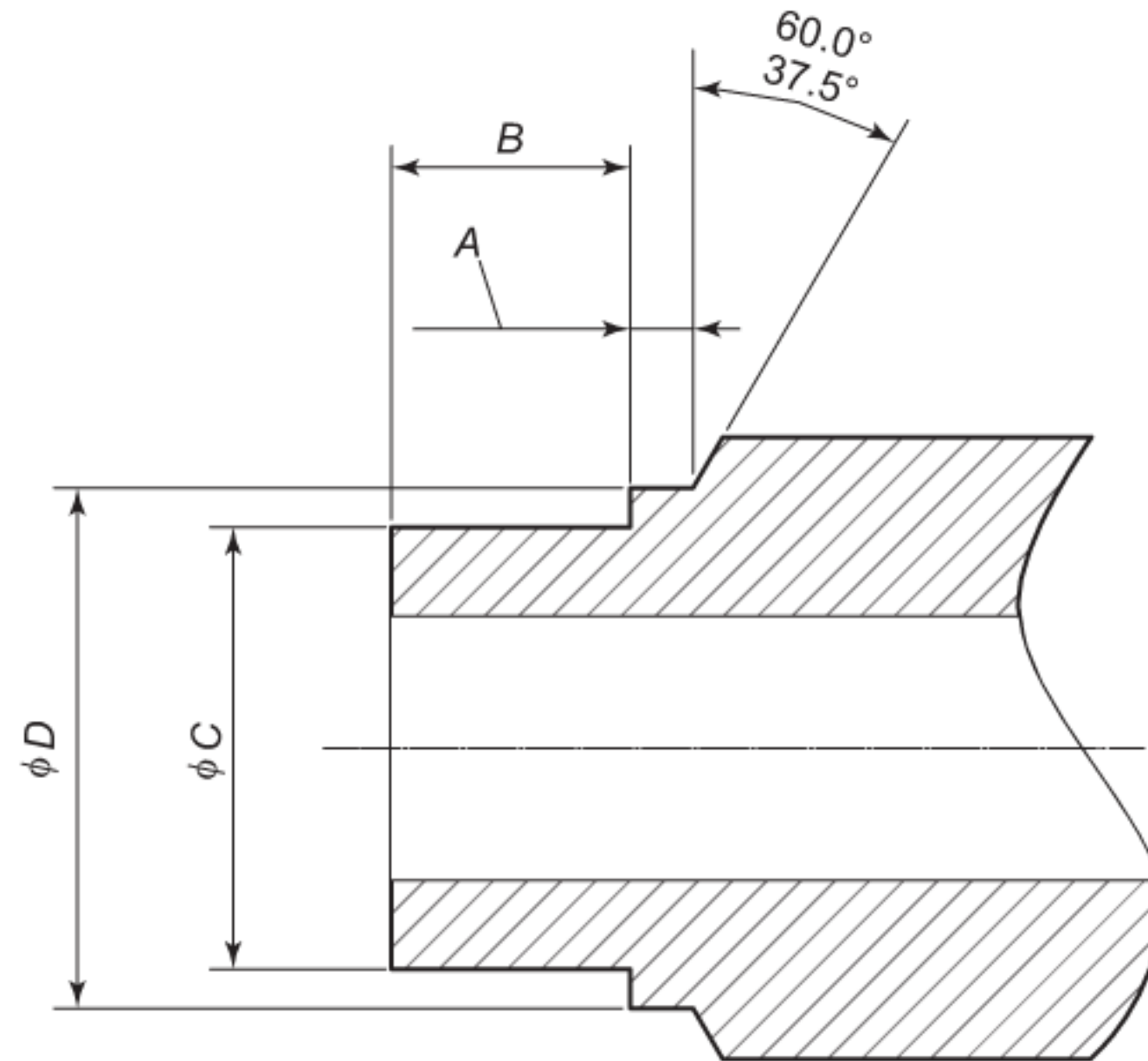
**Figure B.3—Socket Welding End Preparation for Class 800 and Class 1500****Table B.3—Socket Welding End Preparation for Class 800 and Class 1500**

DN	Shoulder Minimum, $A$ mm (in.)	Socket Length, $B$ mm (in.)	Socket Diameter, $C$ mm (in.)	Step Diameter, $D$ mm (in.)	NPS
15	3 (0.12)	7.9 (0.31)	21.3 (0.84)	22.9 (0.90)	1/2
20	3 (0.12)	11.2 (0.44)	26.7 (1.05)	28.2 (1.11)	3/4
25	3 (0.12)	11.2 (0.44)	33.3 (1.31)	35.1 (1.38)	1
40	3 (0.12)	11.2 (0.44)	48.3 (1.90)	49.8 (1.96)	1 1/2
50	3 (0.12)	14.2 (0.56)	60.2 (2.37)	62.0 (2.44)	2

NOTE Tolerances for dimensions  $B$ ,  $C$ , and  $D$ :  $+0.2/-0.8$  mm ( $+0.008/0.030$  in) for  $15 \leq DN \leq 40$  ( $1/2 \leq NPS \leq 1 1/2$ ) and  $\pm 0.8$  mm ( $\pm 0.030$  in) for DN 50 (NPS 2).



## B.4 Materials

An extension welded to a valve body shall be of a material having a nominal chemical composition corresponding to that of the body material and be listed in ASME B16.34. If a tubular form is used it shall be of seamless construction.

## B.5 Body Extension Construction

**B.5.1** An extension shall be cast or forged integral with, or inertial welded to, the body, except that a cast or forged extension attached by full penetration butt-welding may be used when approved by the purchaser. When an extension is attached by welding, the welding operator and welding procedure shall be qualified in accordance with ASME BPVC Section IX. The weld quality shall meet the examination acceptance standards requirements of ASME B31.3 or ISO 15649 as specified for normal fluid service <sup>10</sup>.

**B.5.2** Alignment rings (centering backing rings), integral or loose, used to facilitate welding shall be completely removed after welding. The welded extension and attachment weld shall have no internal tapers, nor other internal discontinuities, where the taper exceeds a four-to-one ratio in the axial to radial directions.

**B.5.3** The final wall thickness of the extension attachment weld shall not be less than that required for the extension by Table B.1 or Table B.2, as applicable.

**B.5.4** Heat treatment following welding, to ensure that the valve body and extension materials are suitable for the full range of service conditions, shall be performed as required by Table B.4, unless otherwise specified by the purchaser.

**Table B.4—Post weld Heat Treatment <sup>e</sup>**

Material	Thickness, $t^a$ mm (in.)	Temperature Range °C (°F)	Holding Time <sup>d</sup> Min/mm (hr/in.)	Weld Hardness HBN Max.
Carbon steels	$t > 20$ ( $t > 0.75$ )	593 to 649 (1100 to 1200)	2.4 (1)	—
Alloy steels:				
Cr $\leq 1/2$ %	$t \leq 20$ ( $t \leq 0.75$ ) and TS $\leq 71$ ksi	None	—	—
Cr $\leq 1/2$ %	All other	593 to 718 (1100 to 1325)	2.4 (1)	225
$1/2$ % $<$ Cr $\leq 2$ %	$t \leq 13$ ( $\leq 1/2$ ) and TS $\leq 71$ ksi	None	—	—
$1/2$ % $<$ Cr $\leq 2$ %	All other	704 to 746 (1300 to 1375)	2.4 (1)	225
$2 1/4$ % $<$ Cr $\leq 10$ %	$t \leq 13$ ( $\leq 1/2$ ) <sup>c</sup>	None	—	—
$2 1/4$ % $<$ Cr $\leq 10$ %	All other	704 to 760 (1300 to 1400)	2.4 (1)	241
Nickel alloy steels	$t > 20$ ( $t > 0.75$ )	593 to 635 (1100 to 1175)	1.2 (1/2)	—
Austenitic steels <sup>b</sup>	All	Solution anneal per material specification		
Other materials	All	Follow material specification and/or Table 331.1.1 of B31.3 requirements		

<sup>a</sup> Thickness,  $t$ , is the greater thickness of the pieces being joined by welding.

<sup>b</sup> Except when materials being welded are L-grades or stabilized grades. See paragraph 5.5.7 for welded or seal welded bonnets.

<sup>c</sup> For material with Cr  $\leq 3$  % and C  $\leq 0.15$  %.

<sup>d</sup> Minimum holding times shall be per ASME B31.3.

<sup>e</sup> Minimum preheat temperatures of B31.3, Table 330.1.1, apply, including those materials exempted from post weld heat treatment.

<sup>10</sup> Normal fluid service is one of several application categories specified in the ISO 15649 by reference to the ASME B31.3 piping code.

**B.5.5** The finished weld shall be free of cracks and shall show no indication of lack of fusion or incomplete penetration. The finished weld shall be ground, or otherwise finished to provide a smoothly contoured surface, and have a surface finish of  $Ra \leq 500 \mu\text{in.}$  ( $Ra \leq 12.5 \mu\text{m}$ ).

## **B.6 Marking**

Valves that have valve bodies with welded end extensions shall be marked with the fabrication markings in accordance with 7.5. In addition, the body marking shall include the material identification for the extension, if different from the body material.

## **Annex C** (normative)

### **Requirements for Valves with Bellows Stem Seals**

#### **C.1 Scope**

This annex specifies design, materials, fabrication, testing and examination requirements for gate and globe valves having bellows stem seals. The requirements stipulated in this annex, in combination with related gate and globe valve requirements in the body of this standard and MSS SP-117, constitute the total requirements for bellows stem seal valves. These requirements are applicable for valves in nominal sizes  $15 \leq DN \leq 50$  ( $1/2 \leq NPS \leq 2$ ).

#### **C.2 Design**

**C.2.1** Bellows stem seals do not eliminate the need for providing the stem packing required by 5.9 and 5.10 or the backseat required by 5.7.7. The packing shall be placed so that it functions as the stem seal in the event that bellows seal leakage occurs (see Figure E.3). Qualification of stem packing shall be based on testing non-bellows seal valves with similar packing design and materials (as per the type testing to meet the fugitive emissions requirements of API 624).

**C.2.2** One end of the bellows shall be attached to the stem just above the gate or to the disc linkage by welding. The opposite bellows end shall be welded either directly to the valve bonnet, to the valve body or to an intervening ring which in turn is either clamped or welded to the bonnet or body. When needed to accommodate large stem strokes, individual bellows may be welded in series.

**C.2.3** Stems in bellows-equipped valves shall be provided with the means to prevent stem rotation and thereby avoid transmitting torsional loads to the bellows.

**C.2.4** Valve-to-bellows assemblies shall be designed so that the bellows convolutions or leaves do not buckle or come into rubbing contact with the surrounding body, the bonnet extension or the enclosed stem.

**C.2.5** The stem shall be designed to provide the strength necessary to accommodate the 38 °C (100 °F) pressure rating taking into consideration any additional pressure area loads imposed by the inclusion of the bellows. The manufacturer shall determine if the stem diameter needs to be increased over that required by 5.7.2.

**C.2.6** A stem-to-gate connection for bellows seal gate valves shall have either a button or T-head end that is designed to fit into a disc slot. Stems shall be constructed in one-piece. Welding or otherwise joining two or more stem pieces is not an acceptable construction.

#### **C.3 Pressure/Temperature Ratings**

**C.3.1** The bellows assembly for a bellows stem seal valve shall be designed to meet the valve pressure rating at 38 °C (100 °F) with the capability of accommodating a pressure test at 1.5 times the 38 °C (100 °F) pressure rating, while preserving the ability to meet the bellows life cycle requirements of Annex D.

**C.3.2** For fluid service above 38 °C (100 °F), the bellows design may limit the valve pressure rating to pressures less than those specified by 4.1 or the temperature to a value less than the maximum specified in 4.1. When this occurs, the valve manufacturer shall publish applicable pressure/temperature ratings and provide these to the user.

**C.3.3** Restrictions of temperature or pressure imposed by the bellows assembly design shall be marked on the identification plate (see 7.4).

**C.3.4** A bellows stem seal valve shall be limited to applications where temperatures are below the creep range of the bellows material. The definition for temperature for the onset of creep shall be in accordance with ASME B16.34.

## C.4 Extensions for Bellows Enclosure

**C.4.1** The cylindrical bonnet or body extension required to enclose a bellows stem seal (see Annex E) shall have a minimum wall thickness the greater of either the body minimum wall thickness specified in Table 5 or the wall thickness specified in Table 6, using two-thirds of the actual local inside diameter of the extension. In the event that the material selected for the extension has a pressure/temperature rating less than the body material, considering the entire material temperature range, the minimum wall thickness of the extension shall be increased, as necessary, so that its pressure/temperature rating equals or exceeds that of the body.

**C.4.2** The bonnet or body extension that envelops the bellows shall be integral, attached by a threaded connection that is seal welded, or attached by welding.

**C.4.3** The weld for an extension that is welded directly to the bonnet or body shall be a full strength butt weld. The welding operator and welding procedure shall be qualified in accordance with ASME *BPVC* Section IX. Heat treatment following welding, to ensure that the bonnet and extension materials are suitable for the full range of service conditions, shall be performed as required by Table B.4. The weld quality shall meet the examination acceptance standards requirements of ASME B31.3 or ISO 15649 as specified for normal fluid service.

## C.5 Type Testing

**C.5.1** The adequacy of each design of bellows and its means of attachment, including attachment welds, shall be verified by type testing in accordance with Annex D.

**C.5.2** A bellows assembly design change that alters cyclic life demonstrated by a type test (e.g. a change in bellows material, bellows thickness, number of plies, welding geometry, or welding procedure) requires an entirely new life cycle type test.

**C.5.3** When the bellows or bellows assembly manufacturer is changed, or there is a change in the method of manufacture of the bellows or bellows assembly, an entirely new life cycle type test is required.

**C.5.4** A change in the number of convolutions of a qualified bellows (increasing or decreasing the overall bellows height) is not of itself cause for a new life cycle test, provided that the installed bellows travel ratio for compression and extension is less than or equal to that of the qualified bellows. These ratios are defined as:

$$R_c = \frac{h_f - h_c}{h_f}$$

and

$$R_e = \frac{h_e - h_f}{h_f}$$

where

$R_c$  is the bellows compression ratio;

$R_e$  is the bellows extension ratio;

$h_f$  is the unrestrained (free) bellows height;

$h_c$  is the installed compressed bellows height;

$h_e$  is the installed extended bellows height.

**C.5.5** A bellows valve shall be designed such that the qualified extension and compression ratios cannot be exceeded.

## C.6 Materials

**C.6.1** Typical materials for bellows are listed in Table C.1. Some services may require special bellows materials. When specified by the purchaser, materials other than those listed in Table C.1 may be selected for the bellows.

**Table C.1—Bellows Material Chart**

Material Type	Typical Specification
304 Stainless	ASTM 240/ASTM A312
304L Stainless	ASTM 240/ASTM A312
316 Stainless	ASTM 240/ASTM A312
316L Stainless	ASTM 240/ASTM A312
321 Stainless	ASTM 240/ASTM A312
347 Stainless	ASTM A240/ASTM A312
Alloy 600	ASTM B167/ASTM B168
Alloy 625	ASTM B443
Alloy 718	ASTM B670
Alloy 400	ASTM B127/ASTM B165
Alloy C22	ASTM B575/ASTM B622
Alloy C276	ASTM B575/ASTM B622

**C.6.2** Fabrication welding operations related to bellows or bellows assemblies shall be performed by qualified welding operators using qualified welding procedures. The welding operator and welding procedure shall be qualified in accordance with ASME BPVC Section IX.

**C.6.3** The attachment welds of bellows and/or bellows end fittings to the valve body or bonnet shall be exempt from postweld heat treatment requirements.

**C.6.4** Bellows material shall not be repaired by welding.

**C.6.5** The bellows material shall be either seamless or longitudinally butt-welded unless otherwise specified by the purchaser.

**C.6.6** The bellows shall be of multi-ply construction unless otherwise specified by the purchaser.

**C.6.7** Bellows assemblies, as received from the bellows manufacturer, shall be contained in individual packages so as to prevent damage from handling or moisture prior to assembly.

## C.7 Pressure Tests

**C.7.1** Prior to assembly, each bellows or bellows assembly shall be tested for leakage using a mass spectrometer leakage testing device having a sensitivity of  $10^{-3}$  mm<sup>3</sup>/s ( $6.1 \times 10^{-8}$  in.<sup>3</sup>/s) of helium at standard atmospheric pressure and 20 °C (70 °F), and shall show no detectable leakage, or other means that the manufacturer can demonstrate to be of equal leakage detection sensitivity.

**C.7.2** Pressure tests for bellows stem seal valves, with the manufacturer taking into account the consequences of a bellows failure during pressure testing, shall be without stem packing installed or with the stem packing adjustment bolting loosely assembled so as to not effect a stem seal.

**C.7.3** When water is used as the test fluid for pressure testing valves having austenitic stainless steel bellows, the chloride content of the test water shall not exceed 50 ppm.

**C.7.4** A backseat test is not required for a valve with a bellows stem seal.

## **C.8 Marking**

**C.8.1** Each bellows assembly shall have a material identification marking.

**C.8.2** The bellows material marking shall appear on the valve identification plate.

## **C.9 Preparation for Dispatch**

After testing, special care shall be taken to drain test fluid from the bellows chamber.

## **Annex D** **(normative)**

### **Type Testing of Bellows Stem Seals**

#### **D.1 Scope**

This annex specifies type testing for the purpose of qualifying bellows and bellows assemblies to be used in gate or globe valves in accordance with this standard. Included are requirements for testing, examination, and acceptability.

#### **D.2 General Requirements**

**D.2.1** The bellows is the expandable metal part that acts as the initial stem seal preventing the contained fluid from escaping into the atmosphere surrounding the valve. A bellows assembly includes the bellows and related end fittings. The end fittings may be in the form of rings, caps or flanges attached to the bellows by welding.

**D.2.2** Each bellows assembly design and each bellows material shall be qualified by type testing. Type testing includes both ambient temperature and high-temperature testing. The ambient temperature tests shall be carried out at a pressure at least equal to the rated valve pressure for 38 °C (100 °F). The high-temperature tests shall be carried out at a pressure at least equal to the rated valve pressure for either a temperature at least equal to 427 °C (800 °F) or the maximum temperature for which the bellows is designated.

**D.2.3** A successful qualification requires that three bellows assemblies of the same design and material be type tested at ambient conditions and three more be tested at the high temperature conditions, and that all six meet the qualification acceptance requirements. The six bellows assemblies for testing shall be randomly selected from a regular bellows assembly production lot.

#### **D.3 Test Procedure**

##### **D.3.1 Pretest Examination**

**D.3.1.1** The bellows assemblies to be tested shall be clean.

**D.3.1.2** The unrestrained (free) height of each bellows shall be measured and recorded along with the compressed and extended heights for which the qualification applies. The compressed and extended ratios (see C.5.4) shall be calculated and recorded in the test report.

**D.3.1.3** All bellows assembly welds shall be examined using a liquid dye penetrant. Any indication of a crack or any other weld defect shall be cause for rejection.

**D.3.1.4** Each bellows assembly shall be subjected to a helium leakage test. The assembly shall show no detectable leakage when tested with an instrument with a sensitivity of  $10^{-3}$  mm<sup>3</sup>/s of helium.

##### **D.3.2 Pressure Test**

**D.3.2.1** Each bellows assembly shall be pressure tested.

**D.3.2.2** The pressure test fluid shall be water containing less than 50 ppm of chlorides.

**D.3.2.3** For the pressure test, the bellows shall be positioned at its compressed design height corresponding to the valve full open position. Positioning may be either in a valve assembly or in a test fixture duplicating the intended valve assembly.

**D.3.2.4** The test fluid pressure shall be applied in the same direction (externally or internally) for which the bellows assembly is to be qualified.

**D.3.2.5** The test fluid pressure shall be not less than 1.5 times the rated pressure of the valve at 38 °C (100 °F).

**D.3.2.6** The minimum pressure test duration shall be five minutes.

**D.3.2.7** Any visually detectable leakage over the test duration shall be cause for rejection.

### **D.3.3 Cycle Test**

**D.3.3.1** Each bellows assembly shall be cycle tested.

**D.3.3.2** For the cycle test, the bellows assembly shall be installed in either a completely assembled valve (with the packing removed) or a test fixture that simulates the intended bellows valve installation and incorporates its maximum possible extension and compression.

**D.3.3.3** The frequency of cycling shall not exceed one cycle per second.

**D.3.3.4** One complete cycle is defined as movement of the bellows from the design compressed position to the design extended position and return to the compressed position corresponding to the valve open-closed-open positions.

**D.3.3.5** The ambient cycle test cycling shall be carried out at ambient temperature and with the bellows subjected to a water pressure, as a minimum, equal to the 38 °C (100 °F) intended valve pressure rating. The high-temperature cycle test shall be carried out at a temperature at least the greater of 427 °C (800 °F) or the maximum bellows assembly rated temperature, and with the bellows subjected to a pressure, as a minimum, equal to the intended valve pressure rating at the test temperature. The test fluid for the high temperature test may be liquid or gas, at the manufacturer's option.

**D.3.3.6** Water containing less than 50 ppm of chlorides shall be used.

**D.3.3.7** The minimum number of test cycles required for qualification for each bellows assembly shall be in accordance with Table D.1.

**Table D.1—Bellows Test Cycles**

Valve Rating	Test Cycles Minimum	
	Gate Valve	Globe Valve
Class ≤ 800	2000	5000
Class > 800	2000	2000

### **D.3.4 Post Test Examination**

**D.3.4.1** Upon completion of the cycle test, repeat the liquid dye penetrant examination of D.3.1.3.

**D.3.4.2** After the liquid dye penetrant examination, each bellows assembly shall be tested for leakage in accordance with either:

- a) submerging the bellows assembly in water for a period of five minutes while applying air at a pressure greater than 5.6 bar (80 psig); or
- b) performing a helium leakage test using an instrument that has a sensitivity of  $10^{-3}$  mm<sup>3</sup>/s of helium.



**D.3.4.3** Any detectable leakage either from the bellows or the bellows assembly welds shall be cause for failure.

#### **D.4 Acceptability**

Acceptance of the bellows assembly design and construction shall be based on all six assemblies meeting the qualification test requirements.

#### **D.5 Test Report**

A test report shall be prepared and be available at the valve manufacturer's facility for review upon purchaser request when such provision is included in the purchase order.

## Annex E (informative)

### Identification of Valve Parts

The purpose of Figure E.1 through Figure E.9 is to identify part names only.

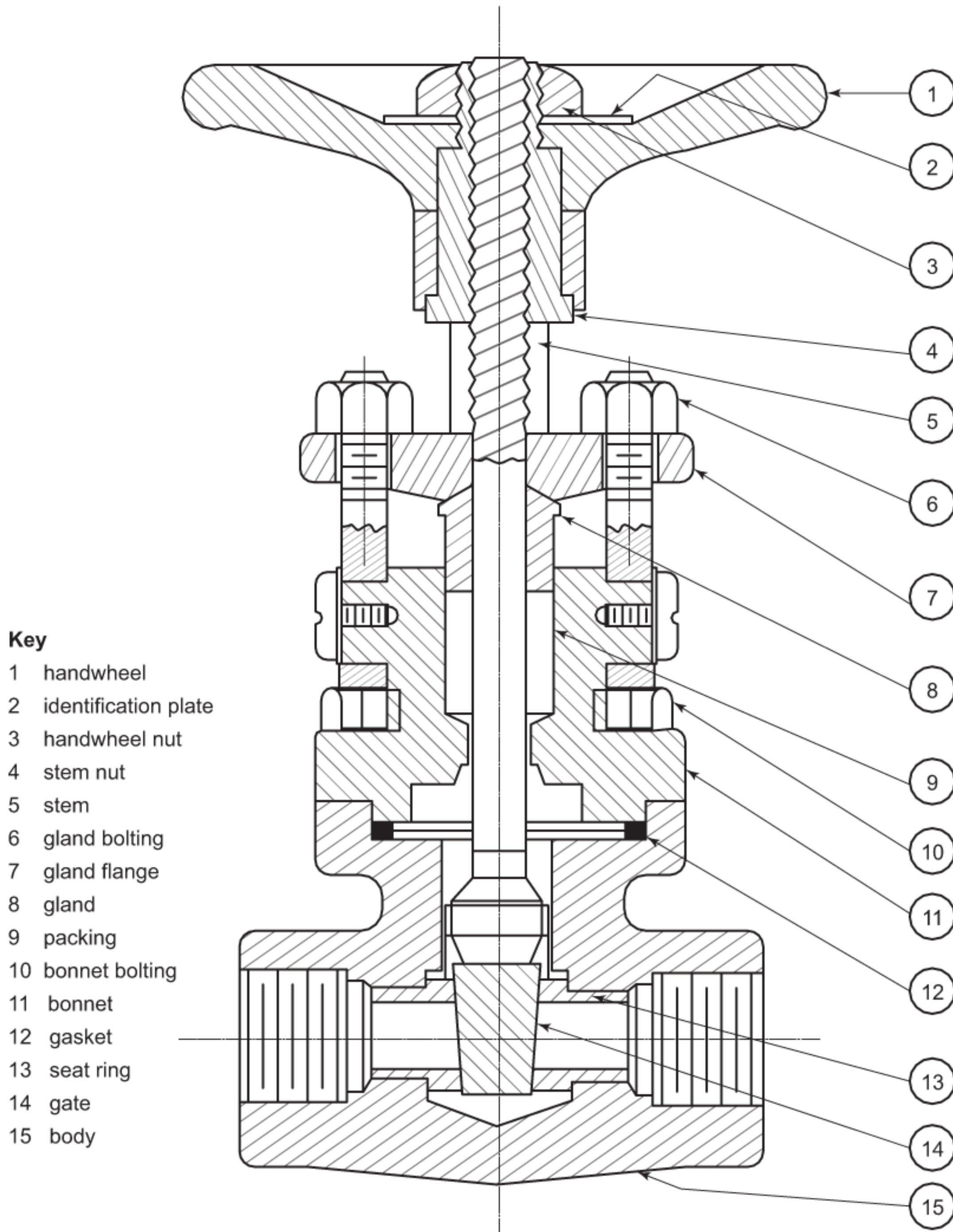
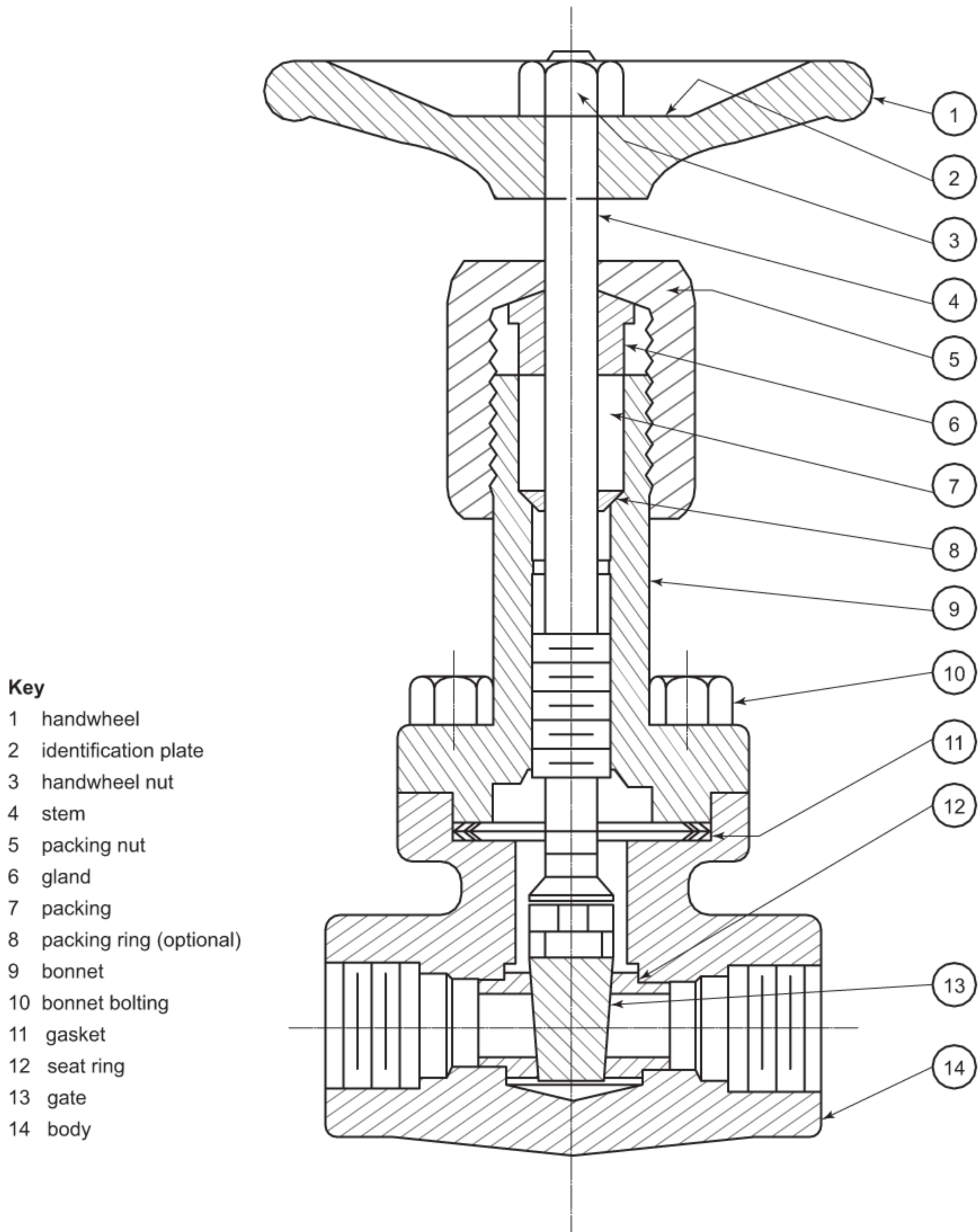
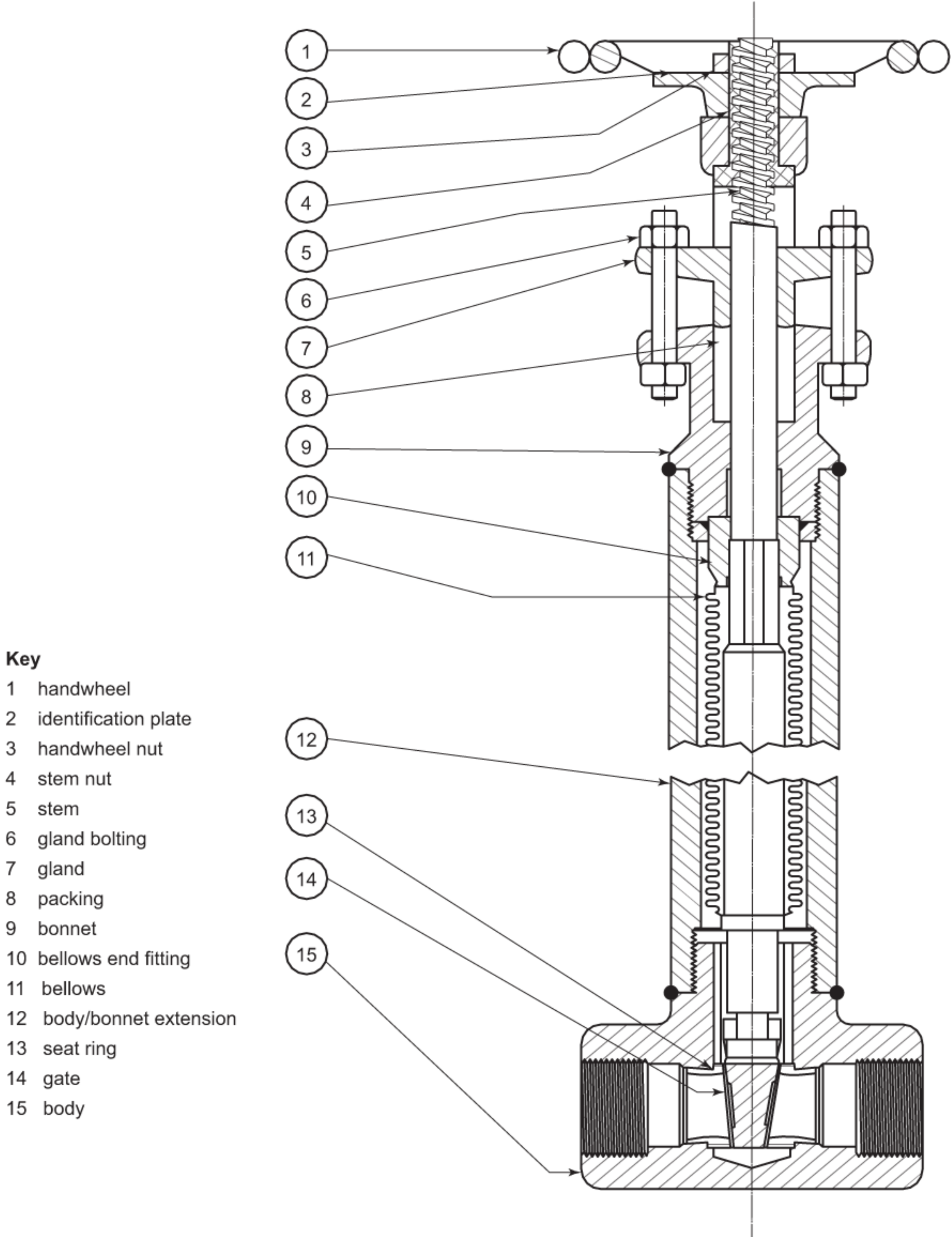

Figure E.1—Outside Screw and Yoke Bolted Bonnet Gate Valve



**Figure E.2—Inside Screw Gate Valve**



**Key**

- 1 handwheel
- 2 identification plate
- 3 handwheel nut
- 4 stem nut
- 5 stem
- 6 gland bolting
- 7 gland
- 8 packing
- 9 bonnet
- 10 bellows end fitting
- 11 bellows
- 12 body/bonnet extension
- 13 seat ring
- 14 gate
- 15 body

**Figure E.3—Bellows Stem Seal Gate Valve**

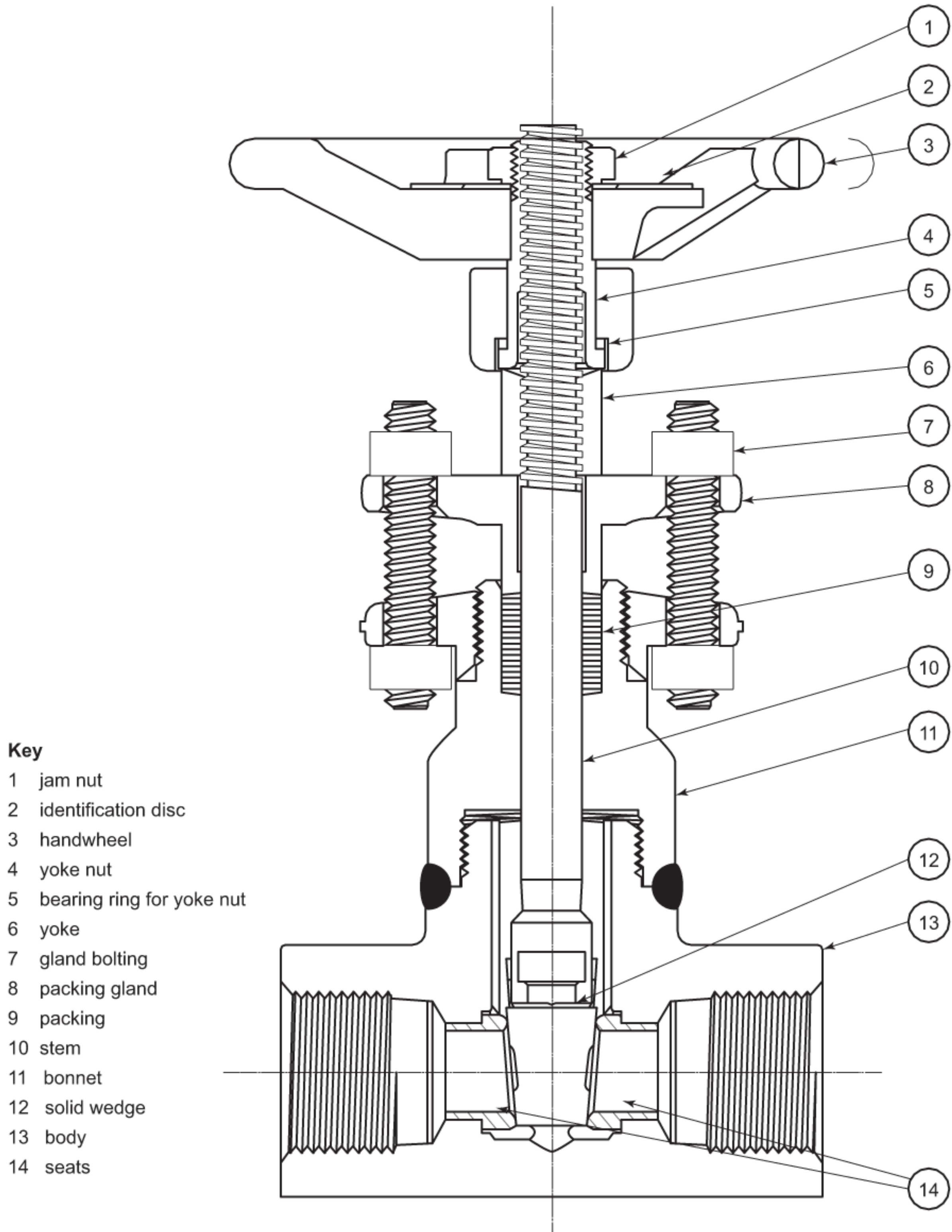
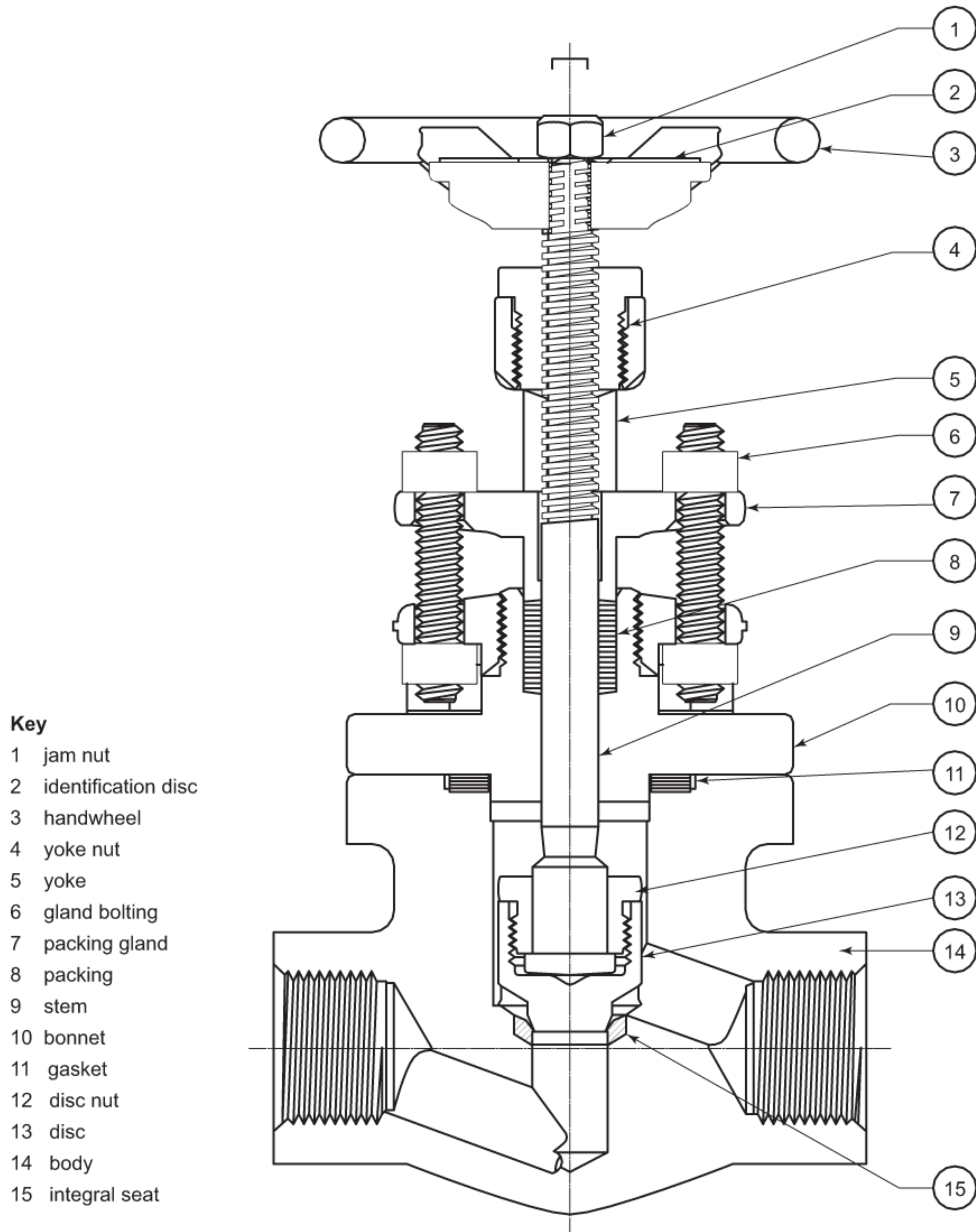

Figure E.4—Welded Bonnet Gate Valve



**Figure E.5—Outside Screw and Yoke Globe Valve**

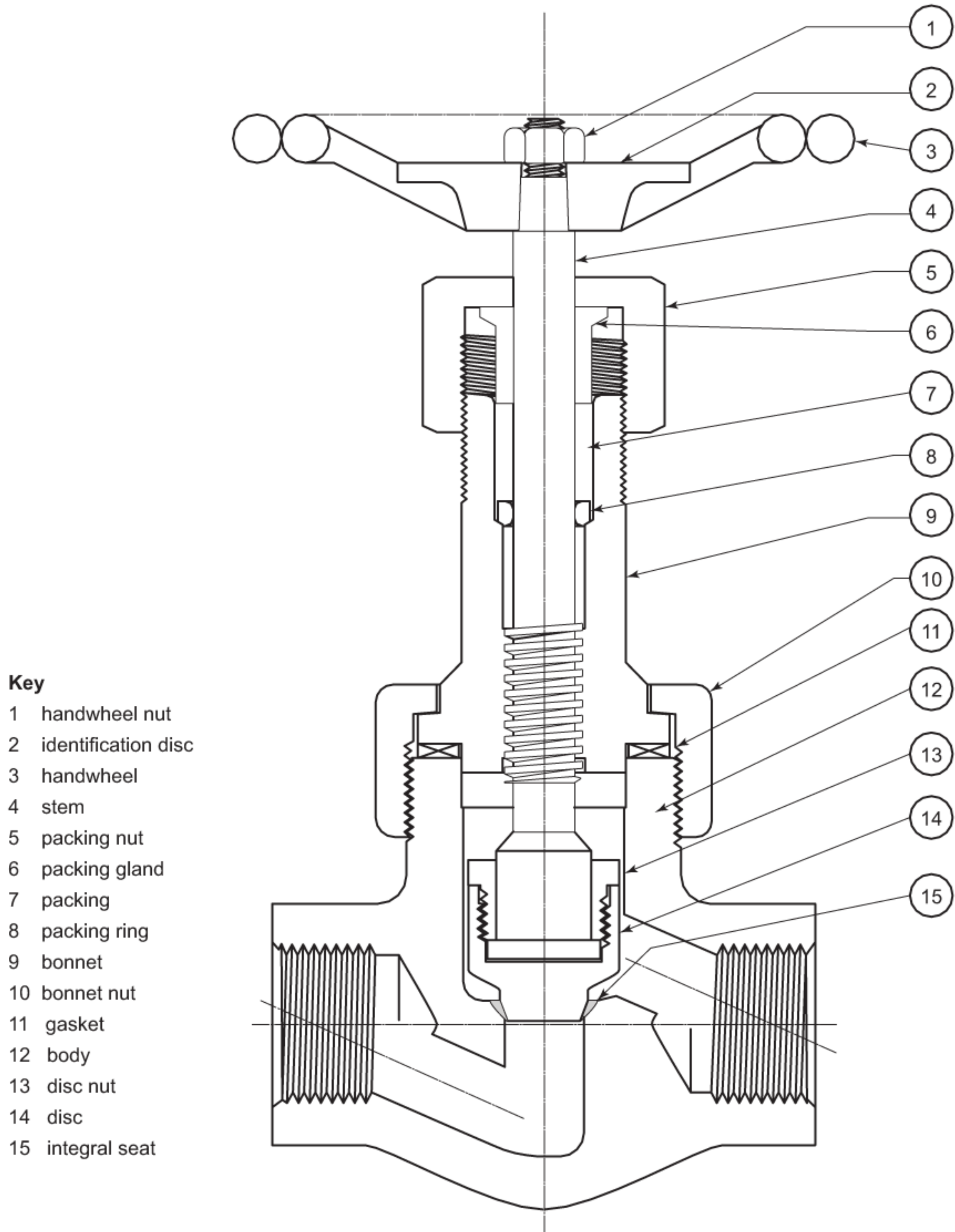
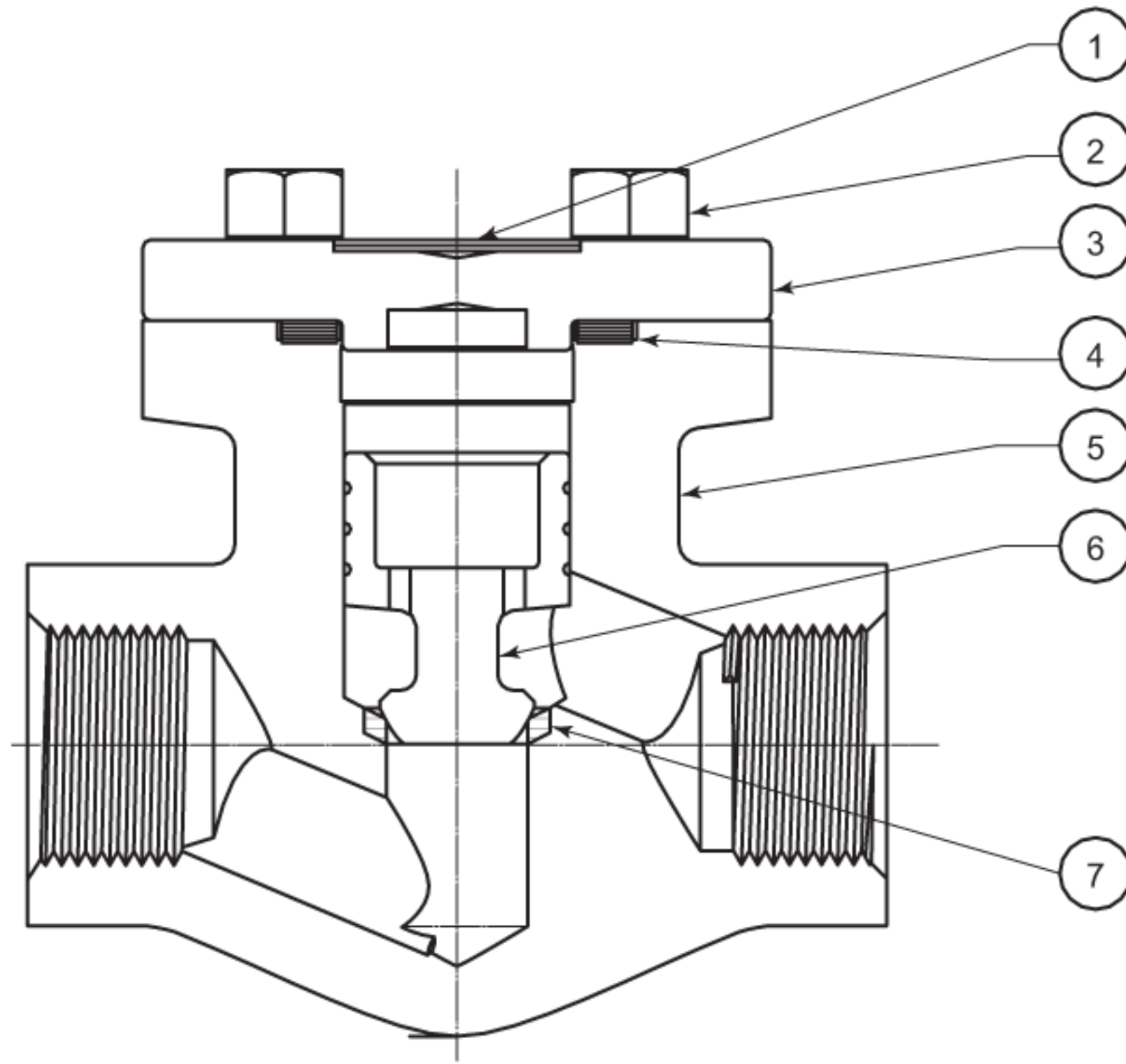

Figure E.6—Union Bonnet Globe Valve

**Key**

- 1 identification disc
- 2 bonnet bolting
- 3 bonnet
- 4 gasket
- 5 body
- 6 disc check
- 7 integral seat



**Figure E.7—Piston Check Valve**

**Key**

- 1 identification disc
- 2 bonnet bolting
- 3 bonnet
- 4 gasket
- 5 body
- 6 ball guide
- 7 ball check
- 8 integral seat

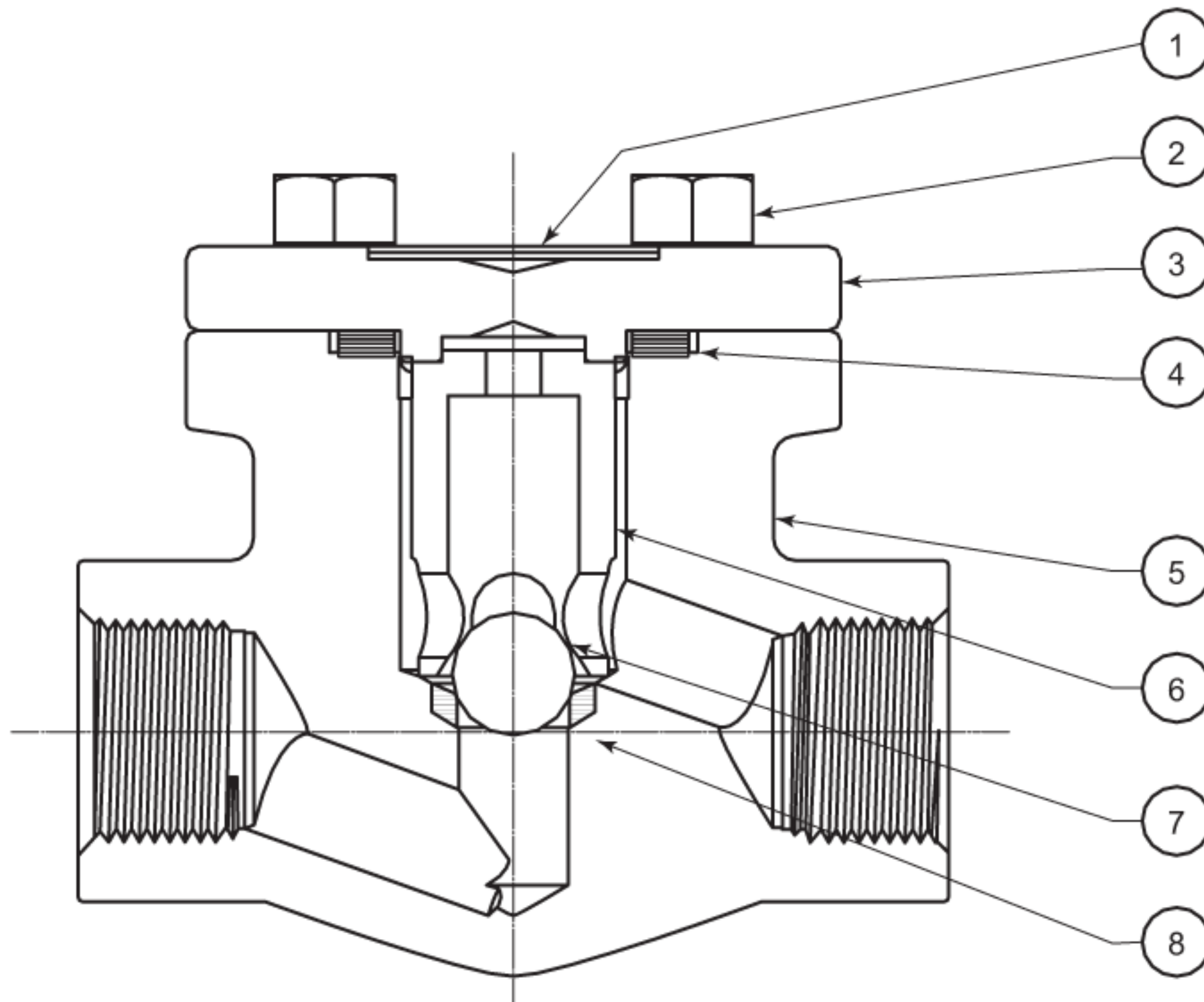
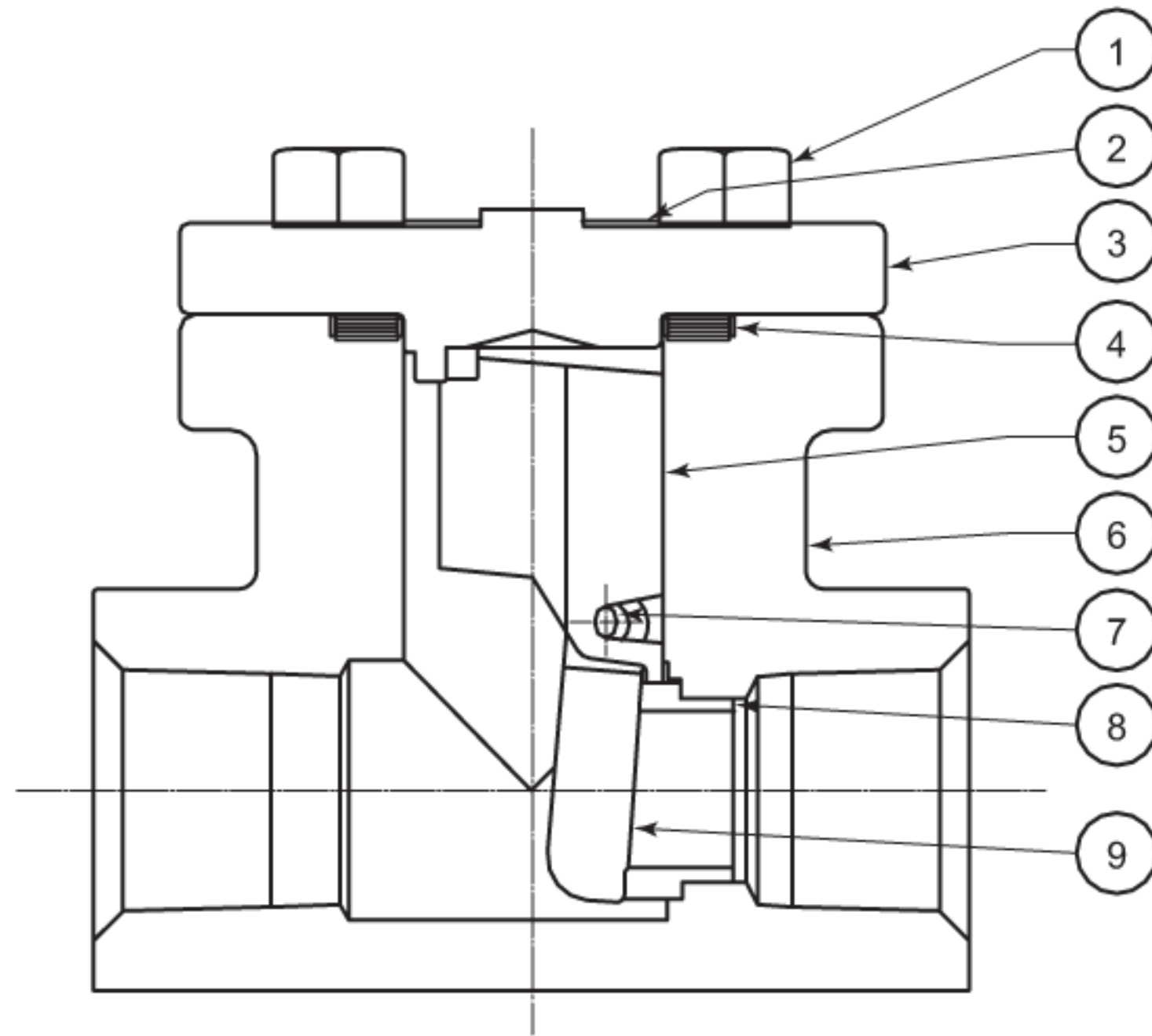

**Figure E.8—Ball Check Valve**



**Key**

- 1 bonnet bolting
- 2 identification disc
- 3 bonnet
- 4 gasket
- 5 swing check support
- 6 body
- 7 pin
- 8 seat
- 9 closure element



**Figure E.9—Swing Check Valve**

## Annex F (normative)

### Information to be Specified by the Purchaser

NOTE Numbers in brackets are references to clauses or subsections of this standard.

**F.1** Supplemental requirements of this standard shall be specifically stated in the purchase order.

**F.2** If no supplemental requirements are to be taken, the purchase order just needs to refer to API 602 and to specify the items in the following list that are marked with a bullet (●) in the margin. The items listed below without a bullet are options that may also be specified.

- a) Valve type [Section 1] (gate, globe or check) (standard bore is the reference standard design, full bore is to be specified) [5.1]. Check valve type [5.6.4.1].
- b) Gate or globe valve type [5.7] (OS & Y is the reference standard design, ISRS to be specified) [Section 5].
- c) Nominal size [Section 1] (NPS or DN).
- d) Pressure class designation [Section 1] (class number).
- e) Body ends [5.4]:
  - 1) threaded (pipe threads ASME B1.20.1) [5.4.3.2];
  - 2) flange facing:
    - raised face or ring joint [5.4.4.1],
    - facing finish if other than standard [5.4.4.1];
  - 3) socket welding [5.4.2];
  - 4) butt-welding [5.4.5].
- f) Extended body ends [B.1]:
  - 1) external:
    - butt-welding [B.3.3],
    - socket welding [B.3.3],
    - threaded [B.3.2];
  - 2) internal:
    - threaded [B.2.3],
    - socket welding [B.2.3].

- g) Material [Section 6]:
  - 1) pressure-containing shell [Table 1 and Table 14];
  - 2) forging material is the reference standard design for  $DN \leq 50$  ( $NPS \leq 2$ ) other materials may be specified [5.1.3];
  - 3) bellows [C.7.1].
- h) Trim [6.1]:
  - 1) combination number [6.1.1];
  - 2) trim using free-machining materials [6.1.2];
  - 3) alternative trim [6.1.3];
  - 4) bonnet bolting [Table 14 and Annex G];
  - 5) gasket [5.5.3];
  - 6) packing [Table 14].
- i) Alternative seat design (globe) [5.6.3.1].
- j) Optional high-pressure closure test [see API 598].
- k) Alternative backseat test method [see API 598].
- l) Flanges attached by welding [5.4.4.2].
- m) Metric or inch series body to bonnet bolting [5.5.5].
- n) Extended body extensions attached by welding B.5.1].
- o) Seamless or welded bellows material [C.6.5].
- p) Multiply or other bellows construction [C.6.6].
- q) Special packaging [9.8].
- r) Compliance with NACE MR 0103 [6.3].

## Annex G (informative)

### Valve Material Combinations

Table G.1, Table G.2, and Table G.3 list valve body, bonnet, and cover materials (ASME B16.34, *Material Groups 1, 2 and 3*) along with associated valve trim materials (CN designations, Table 14) and ASTM A193, ASTM A194, and nickel alloy bolting materials.

**Table G.1—Material Combinations for Group 1 Body, Bonnet, and Cover Materials**

Material Group ASME B16.34	Body/Bonnet Material Abbreviation	Body, Bonnet, and Cover ASTM Specification	Typical Trim Material CN Designation	Body-to-bonnet and Body-to-cover Bolting ASTM Specification <sup>a</sup>
1.1	C-Si	A105 or A216-WCB	8	B7/2H
	C-Mn-Si	A350-LF2-CL1	8 <sup>g</sup>	B7/2H <sup>b</sup>
	C-Mn-Si-V	A350-LF6-CL1	10	B8M-CL2/8M <sup>b c d</sup>
	3 <sup>1</sup> / <sub>2</sub> Ni	A350-LF3	10	B8M-CL2/8M <sup>b c d</sup>
1.2	C-Mn-Si	A216-WCC	8	B7/2H
		A352-LCC	8	B7/2H <sup>b</sup>
	C-Mn-Si-V	A350-LF6-CL2	10	B8M-CL2/8M <sup>b c d</sup>
	2 <sup>1</sup> / <sub>2</sub> Ni	A352-LC2	10	B8M-CL2/8M <sup>b c d</sup>
	3 <sup>1</sup> / <sub>2</sub> Ni	A352-LC3	10	B8M-CL2/8M <sup>b c d</sup>
1.3	C-Si	A352-LCB	8	B7/2H <sup>b</sup>
	C- <sup>1</sup> / <sub>2</sub> Mo	A217-WC1	8	B7/2H
		A352-LC1	10	B8M-CL2/8M <sup>b c d</sup>
1.4	C-Mn-Si	A350-LF1	8	B7/2H <sup>b</sup>
1.5	C- <sup>1</sup> / <sub>2</sub> Mo	A182-F1	8	B7/2H
1.7	<sup>1</sup> / <sub>2</sub> Cr- <sup>1</sup> / <sub>2</sub> Mo	A182-F2		
	Ni- <sup>1</sup> / <sub>2</sub> Cr- <sup>1</sup> / <sub>2</sub> Mo	A217-WC4	8	B7/2H
	<sup>3</sup> / <sub>4</sub> Ni- <sup>3</sup> / <sub>4</sub> Cr-1Mo	A217-WC5		
1.9	<sup>1</sup> / <sub>4</sub> Cr- <sup>1</sup> / <sub>2</sub> Mo	A217-WC6		
	<sup>1</sup> / <sub>4</sub> Cr- <sup>1</sup> / <sub>2</sub> Mo-Si	A182-F11-CL2	8	B16/8M <sup>e</sup>
1.10	2 <sup>1</sup> / <sub>4</sub> Cr-1Mo	A182-F22-CL3		
		A217-WC9	8	B16/8M <sup>e</sup>
1.11	3Cr-1Mo	A182-F21	8	B16M/8M <sup>e</sup>
1.13	5Cr- <sup>1</sup> / <sub>2</sub> Mo	A182-F5a or A217-C5	8	B16/8M <sup>e</sup>
1.14	9Cr-1 Mo	A182-F9 or A217-C12	8	B16/8M <sup>e</sup>
1.15	9Cr-1Mo-V	A182-F91 or A217-C12A	8	B16/8M <sup>e</sup>
1.17	1Cr- <sup>1</sup> / <sub>2</sub> Mo	A182-F12-CL2		
	5Cr- <sup>1</sup> / <sub>2</sub> Mo	A182-F5	8	B16/8M <sup>e</sup>
1.18	9Cr-2W-V	A182-F92	8	B16M/8M <sup>e</sup>

NOTE For Table G.1 table notes, see Table G.2.

**Table G.2—Material Combinations for Group 2 Body to Bonnet Materials**

Material Group ASME B16.34	Body/Bonnet Material Abbreviation	Body, Bonnet, and Cover ASTM Specification	Typical Trim Material CN Designation	Body-to-bonnet and Body-to-cover Bolting ASTM Specification <sup>a</sup>
2.1	18Cr-8Ni	A182-F304/A351-CF3 A182-F304H/A351-CF8	10	B8M-CL2/8M <sup>c d</sup>
2.2	16Cr-12Ni-2Mo 18Cr-8Ni 18CR-13Ni-3Mo 19Cr-10Ni-3Mo	A182-F316 or A351-CF3M, A182-F316H or A351-CF8M A351 CF3A A182-F317 or A182-F317H or A351 CF8A A351-CG8M	10	B8M-CL2/8M <sup>c d</sup>
2.3	18Cr-8Ni 16Cr-12Ni-2Mo	A182-F304L A182-F316L	10	B8M-CL2/8M <sup>c d</sup>
2.4	18Cr-10Ni-Ti	A182-F321 A182-F321H	10	B8M-CL2/8M <sup>c d</sup>
2.5	18Cr-10Ni-Cb	A182-F347H A182-F347 A182-F348 A182-F348H	10	B8M-CL2/8M <sup>c d</sup>
2.7	25Cr-20Ni	A182-F310	10	B8M-CL2/8M <sup>c d</sup>
2.8	20Cr-18Ni-6Mo 22Cr-5Ni-3Mo-N 25Cr-7Ni-4Mo-N 24Cr-10Ni-4Mo-V 25Cr-5Ni-2Mo-3Cu 25Cr-7Ni-3.5MO-W-Cb 25Cr-7Ni-3.5Mo-N-Cu-W	A182-F44 or A351-CK3MCuN A182-F51 or A995 4A CD3MN A182-F53 A995-CE8MN A351-CD4MCu A351-CD3MWCuN A182-F55	f	B8M-CL2/8M <sup>c d</sup>
2.10	25Cr-12Ni	A351-CH8 A351-CH20	f	B8M-CL2/8M <sup>c d</sup>
2.11	18Cr-10Ni-Cb	A351-CF8C	f	B8M-CL2/8M <sup>c d</sup>
2.12	25Cr-20Ni	A351-CK20	f	B8M-CL2/8M <sup>c d</sup>

<sup>a</sup> Temperature limitations on bolting are as follows: Gr B7, 538 °C (1000 °F); Gr L7, 538 °C (1000 °F), Gr B16, 595 °C (1100 °F); Gr B8-CL1, Gr B8A-CL1A, Gr B8M-CL1, and Gr B8MA-CL1A, 816 °C (1500 °F), Gr B8-CL2, Gr B8M-CL2, Gr B8M2-CL2B and Gr B8M3-CL2C, 538 °C (1000 °F).

<sup>b</sup> ASTM A320, Gr L7 bolts, and ASTM A194, Gr 4 nuts may also be used.

<sup>c</sup> ASTM A193, Gr B8-CL1, Gr B8A-CL1A, Gr B8M-CL1, Gr B8MA-CL1A, Gr B8M2-CL2B, and Gr B8M3-CL2C bolting are suitable substitutes provided that the requirements of 5.5.6 are met.

<sup>d</sup> ASTM A193, Gr B8-CL2 bolts may also be used.

<sup>e</sup> ASTM A194, Gr 7 nuts may also be used.

<sup>f</sup> Trim material is not specified, however, trim material shall have corrosion resistance equal to the corrosion resistance of the valve body material.

<sup>g</sup> Temperature limitation on Trim 8: -29 °C (-20 °F) minimum, unless notch toughness tested. Trim 12 or 16 may also be used.

**Table G.3—Material Combinations for Group 3 Body to Bonnet Materials**

Material Group ASME B16.34	Body/Bonnet Material Abbreviation	Body, Bonnet, and Cover ASTM Specification	Typical Trim Material CN Designation	Body-to-bonnet and Body-to- cover Bolting ASTM Specification
3.1	35Ni-35Fe-20Cr-Cb	B-462 N08020	13	B473 N08020 <sup>a d</sup>
3.2	99Ni	B 564 N02200	9	B164 N04400/N04405 <sup>a b c d</sup>
3.4	67Ni-30Cu 67Ni-30Cu-S	B564 N04400 A494 M35-1 A494 M35-2	9	B164 N04400/N04405 <sup>a b c d</sup>
3.5	72Ni-15Cr-8Fe	B564 N06600	19	B166 N06600 <sup>a b d</sup>
3.6	33Ni-42Fe-21Cr	B564 N08800	19	B408 N08800/N08810 <sup>a b c d</sup>
3.7	65Ni-28Mo-2Fe 65Ni-28Mo-2Fe 64Ni-29.5Mo-2Cr-2Fe-Mn-W 64Ni-29.5Mo-2Cr-2Fe-Mn-W	B 462 N10665 B564 N10665 B462 N10675 B564 N10675	19	B335 N10665/N10675 <sup>a d</sup>
3.8	54Ni-16Mo-15Cr 54Ni-16Mo-15Cr 60Ni-22Cr-9Mo-3.5Cb 42Ni-21.5Cr-3Mo-2.3Cu 55Ni-21Cr-13.5Mo 55Ni-21Cr-13.5Mo 59Ni-23Cr-16Mo-1.6Cu 59Ni-23Cr-16Mo-1.6Cu	B462 N10276 B564 N10276 B564 N06625 B564 N08825 B462 N06022 B564 N06022 B462 N06200 B564 N06200	19	B574 N10276/N06022 <sup>a d e</sup> B408 N08800/N08810 <sup>a b c d</sup>
3.12	46Fe-24Ni-21Cr-6Mo-Cu-N  58Ni-33Cr-8Mo 58Ni-33Cr-8Mo	B462 N08367 A351 CN3MN B462 N06035 B564 N06035	19	B691 N08367 <sup>a d</sup>
3.13	31Ni-33Fe-22Cr-6.5Mo-Cu-N	B564 N08031	19	B574 N10276/N06022 <sup>a d e</sup> B581 N06975 <sup>a d</sup>
3.15	42Ni-2Fe-21Cr Ni-Mo Ni-Mo-Cr	B564 N08810 A494 N-12MV A494 CW-12MW	19	B408 N08800/N08810 <sup>a b c d</sup>
3.17	29Ni-20½Cr-3½Cu-2½Mo	A351 CN7M	19	B574 N10276/N06022 <sup>a d e</sup>

Additional details are as follows:

- Repair welding of bolting is not permitted.
- Bolting threads shall be in accordance with ASME B1.1 for inch dimensional bolting and ASME B1.13M for metric bolting.
- Bolting temperature limitation shall be in accordance with ASME Section II, Part D, Table 3.
- Other bolting from Tables G.1, G.2, or G.3 may be substituted by agreement with purchaser and valve provider. Substitute bolting temperature capability shall support the pressure-temperature rating of the valve.

<sup>a</sup> Nuts may be of the same material or may be of compatible grade of ASTM A194.

<sup>b</sup> Forging quality not permitted unless the producer last heating or working these parts tests them as required for other permitted conditions in the same specification and certifies their final tensile, yield, and elongation properties to equal or exceed the requirements for one of the other permitted conditions.

<sup>c</sup> Maximum operating temperature is arbitrarily set at 260C (500F), unless material has been annealed, solution annealed, or hot finished, because hard temper adversely affects design stress in the creep-rupture temper range.

<sup>d</sup> Use annealed material only.

<sup>e</sup> Not to be used over 677 °C (1250 °F).

## Bibliography

- [1] ASME B31T, *Standard Toughness Requirements for Piping*
- [2] ASTM A193, *Standard Specification for Alloy-steel and Stainless Steel Bolting Materials for High-temperature Service*
- [3] ASTM A194, *Standard Specification for Carbon and Alloy Steel Nuts for Bolts for High Pressure and High-Temperature Service, or Both*
- [4] MSS SP-141, *Multi-Turn and Check Valve Modifications*
- [5] MSS SP-134, *Valves for Cryogenic Service Including Requirements for Body/Bonnet Extensions*
- [6] ISO 14723, *Petroleum and natural gas industries—Pipeline transportation systems—Subsea pipeline valves*
- [7] ISO 28921-1, *Industrial valves—Isolating valves for low temperature applications—Part 1: Design, manufacturing and production testing*









AMERICAN PETROLEUM INSTITUTE

1220 L Street, NW  
Washington, DC 20005-4070  
USA

202-682-8000

**Additional copies are available online at [www.api.org/pubs](http://www.api.org/pubs)**

Phone Orders: 1-800-854-7179 (Toll-free in the U.S. and Canada)  
303-397-7956 (Local and International)  
Fax Orders: 303-397-2740

Information about API publications, programs and services is available  
on the web at [www.api.org](http://www.api.org).

**Product No. C60210**